

InCore® TMT System Precision Guided Correction

Surgical Technique



InCore TMT System

Precision Guided Correction

- **Fully Guided**

- Post and Targeting Guide utilize anatomical land marks to facilitate fixation placement

- **Solid Intermedullary Construct**

- Solid 4.9mm Titanium Post provides large surface area engagement in the cancellous bone of the cuneiform
- Headless compression screws thread directly into the 4.9mm post
- Post and screws construct may reduce hardware prominence and resultant hardware removal due to pain or irritation related to such hardware prominence

- **Joint Preparation**

- Targeting Guide provides distraction of the joint for visualization and joint preparation
- Distraction allows space for curettage and microfracture

- **Controlled Compression**

- Targeting Guide includes built-in Compression-Distracton Fixture providing compression parallel to the long axis of the metatarsal

- **Features**

- 4.9mm x 18mm Titanium Post
- 2.7mm Diameter Headless Compression Screws offered from 16 to 52mm in length
- Robust T8 Hexalobe Driver

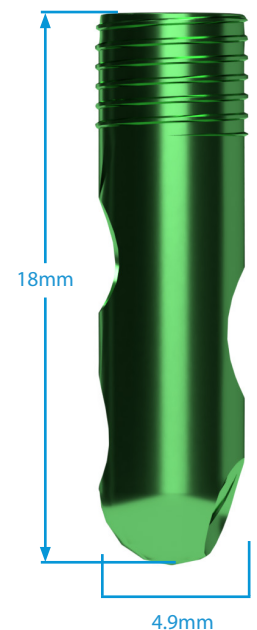

Surgical Technique

1. Prepare instrumentation by first ensuring the top line of the **Compression-Distraction Fixture** is aligned with the start line of the **Targeting Guide**. The **T8 Driver** is used to rotate the **Screw**, causing the **Compression-Distraction Fixture** to travel along the **Targeting Guide**. Improper alignment may restrict potential distraction and compression travel of the **Compression-Distraction Fixture**.

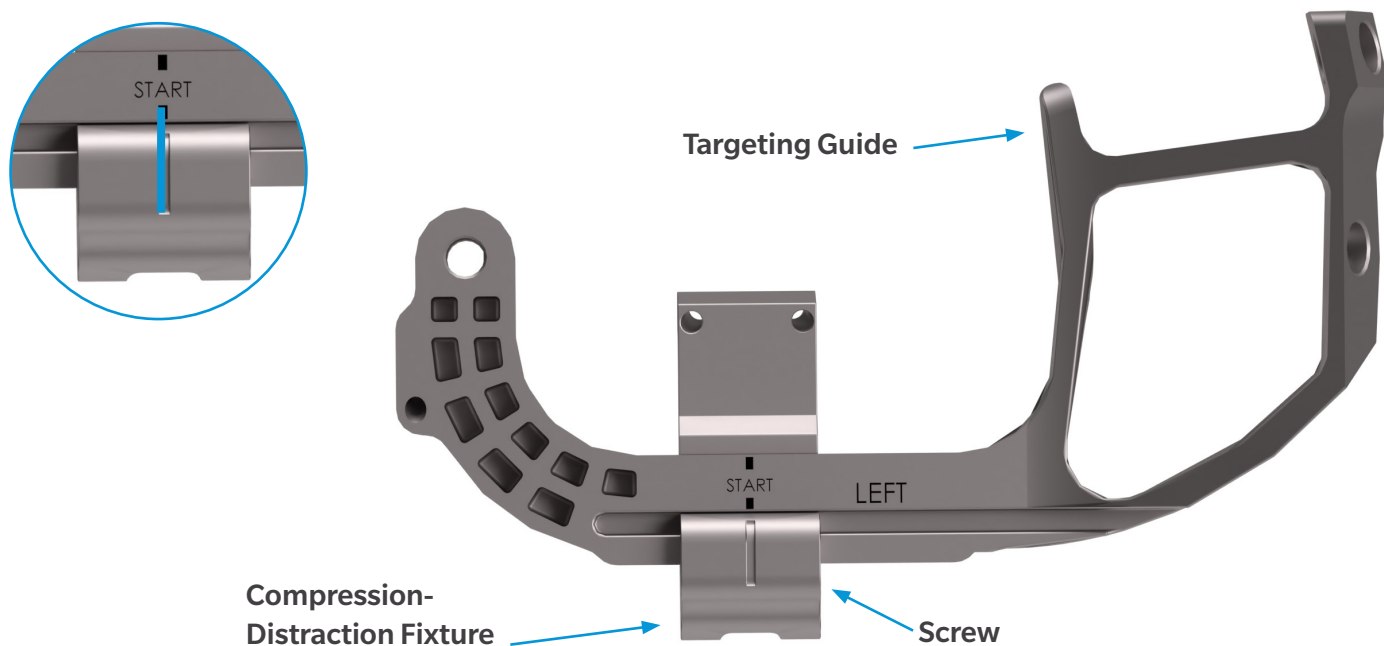

2. Assemble the **InCore TMT Post** to the **Targeting Guide**. Thread the **Post Fastener** into the implant **Post**, with the **Targeting Guide** positioned between. The **Targeting Guide** "tooth" should be aligned with the slot in the top of the **Post**. After firm hand tightening of the **Post Fastener**, there will be no gap or play between the components.

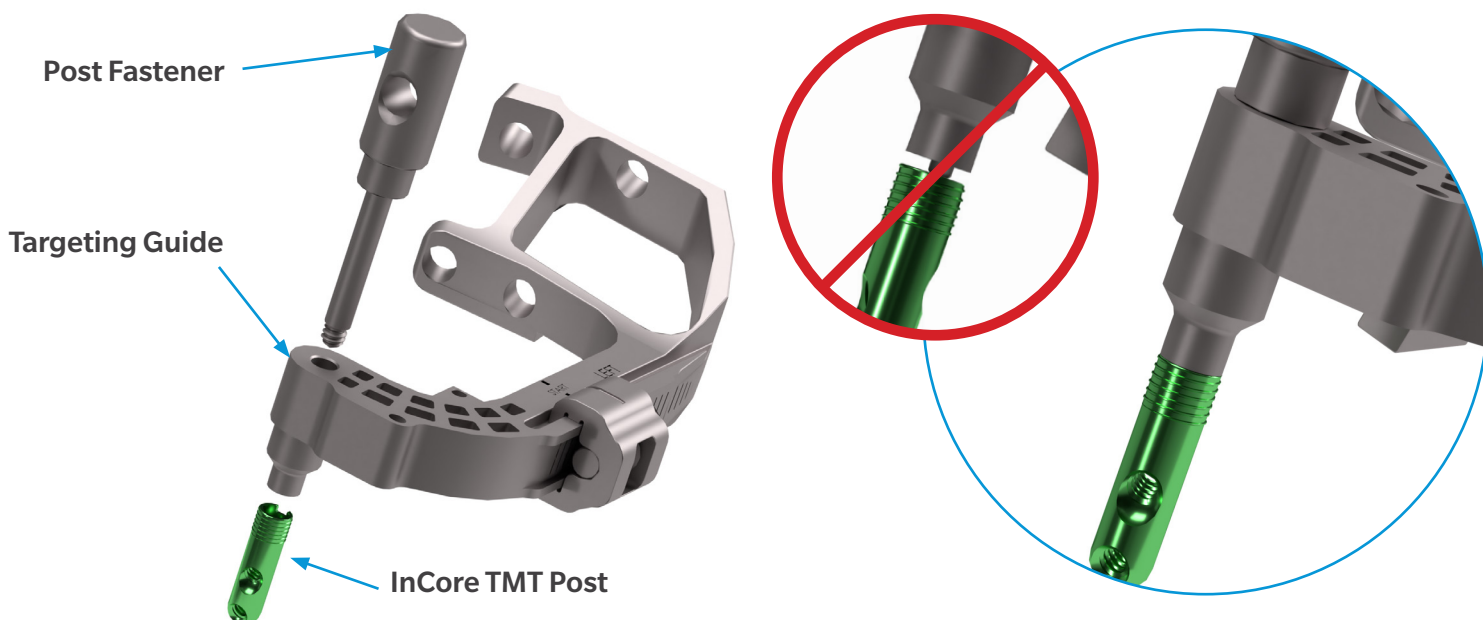

3. Sighting the holes in the **Targeting Guide**, alignment can be visualized to ensure proper assembly and left/right foot selection. The *medial hole* of the **Targeting Guide** aligns with the *plantar hole* in the **Post**. The *lateral hole* of the **Targeting Guide** aligns with the *dorsal hole* of the **Post**.

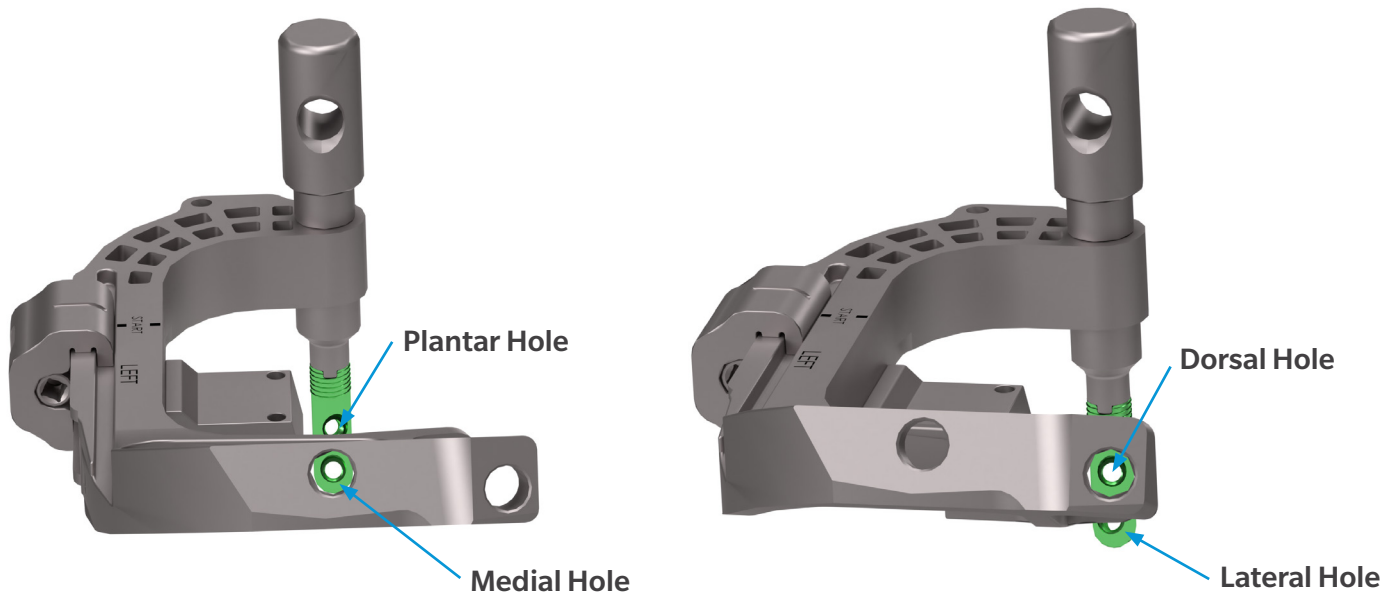

4. Make a dorsal incision over the tarsometatarsal joint.
5. Perform soft tissue releases to ensure full mobility of the 2nd or 3rd metatarsal to the desired correction position.
6. Position the **Post Guide** so that the paddle is aligned with the TMT joint line on the 2nd or 3rd metatarsal and the feet are resting on the cuneiform and metatarsal. (2nd metatarsal procedure shown.)

NOTE: If performing procedure on the 2nd TMT joint, bias **Post Guide** distally 2-3mm.



7. Before placing a **2mm K-wire**, loosely place the **K-wire** into the **Post Guide** and observe the angle of the **K-Wire** to be perpendicular to the long axis of the metatarsal. Adjust as necessary and place **K-wire** through the **Post Guide** and into the bone.

NOTE: If planning to cut the cuneiform for bone preparation, you may consider making cut prior to placing **K-wire**.

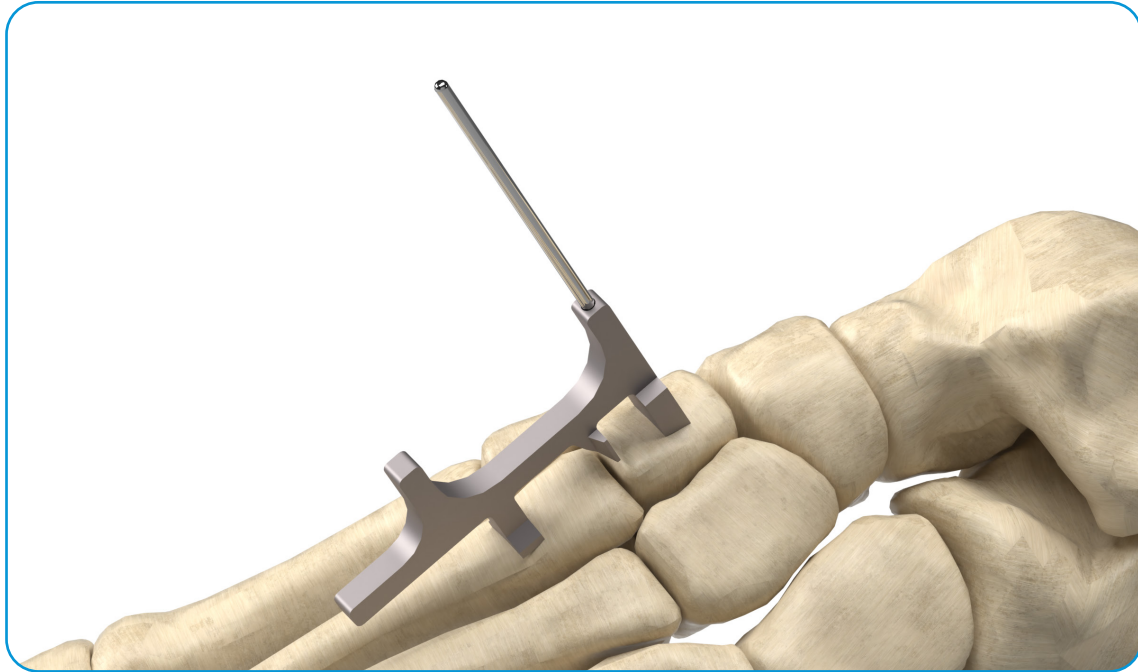

8. Remove the **Post Guide**, leaving the **2mm K-wire** in the bone.

NOTE: The guide is configured to aid in placing the K-wire perpendicular to the long axis of the metatarsal. The angle of the K-wire with respect to the medial aspect of the cuneiform as well as X-ray or fluoroscopy should be assessed to ensure the K-wire is surrounded by adequate bone for reaming, and to ensure the naviculocuneiform (NC) joint will not be violated. There must be at least 18mm of tunnel to ensure the post is appropriately seated in the bone. Adjust K-wire when necessary to account for variations in anatomy.

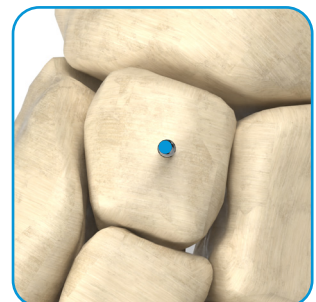
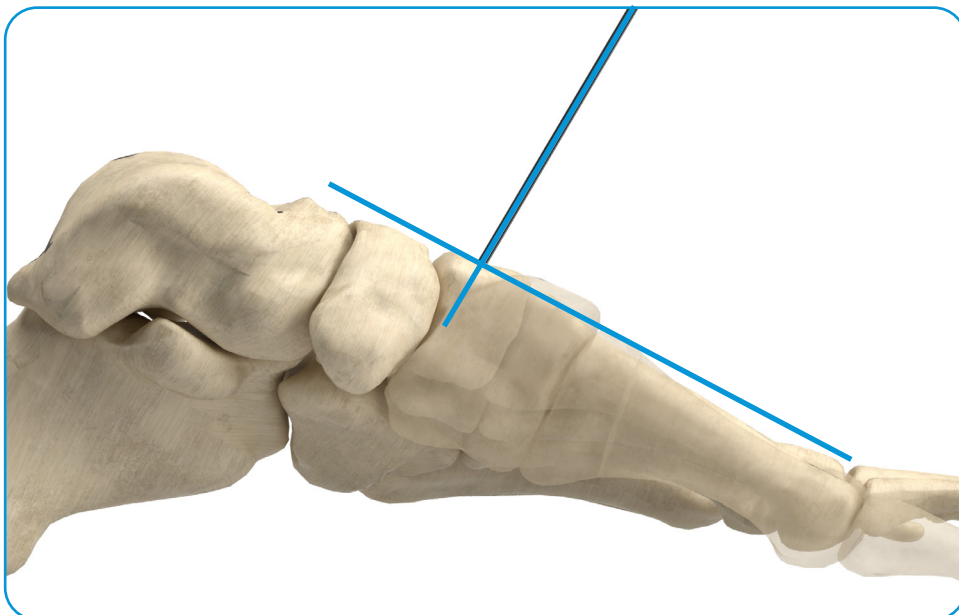

9. Insert the **4.9mm Post Drill** over the **2mm K-wire** and drill to the hard stop.



10. Insert the **Post and Targeting Guide Assembly** into the hole located in the cuneiform. Fully seat the **Post** into the bone ensuring the **Targeting Guide** is at or just below bone surface.

NOTE: Light malleting may be required to fully seat post.

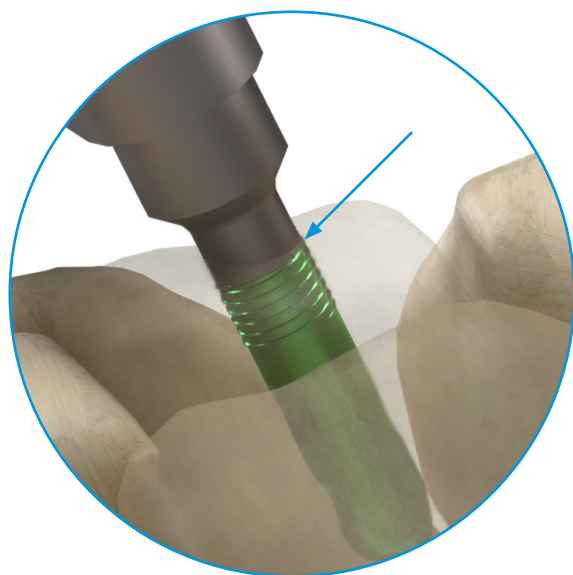

11. Manipulate the metatarsal to achieve desired positioning.

With the **Compression-Distract Fixtue** over the metatarsal, place **Implant Bushings** through the **Targeting Guide** holes. Evaluate the anticipated screw entry points on the metatarsal to ensure that the lateral screw and the medial **2mm K-wires** will have bone purchase. Proper depth of the **Post**, rotation of the **Targeting Guide** about the **Post**, and degree of bone removal during joint preparation are elements that can affect the entry point of screws in the metatarsal.

Once the metatarsal and targeting guide are positioned in the desired location, place two **2mm K-wires** through the **Compression-Distract Fixtue** and into the metatarsal to stabilize positioning.

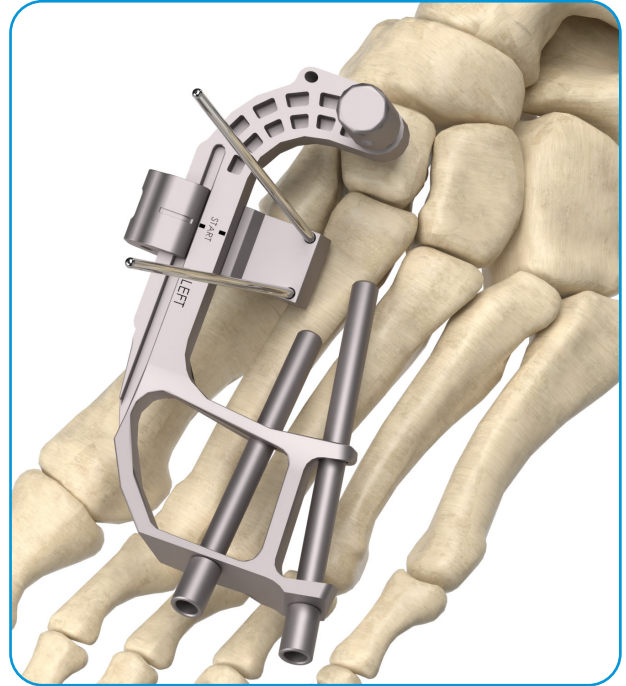

12. Positioning can be maintained by inserting a **2mm K-wire** through the proximal **Targeting Guide** and into the cuneiform, proximal to the post as necessary. When inserting the **2mm K-wire**, check to ensure it is clear of the neurovascular bundle. Once desired positioning has been made, the **Implant Bushings** can be removed.

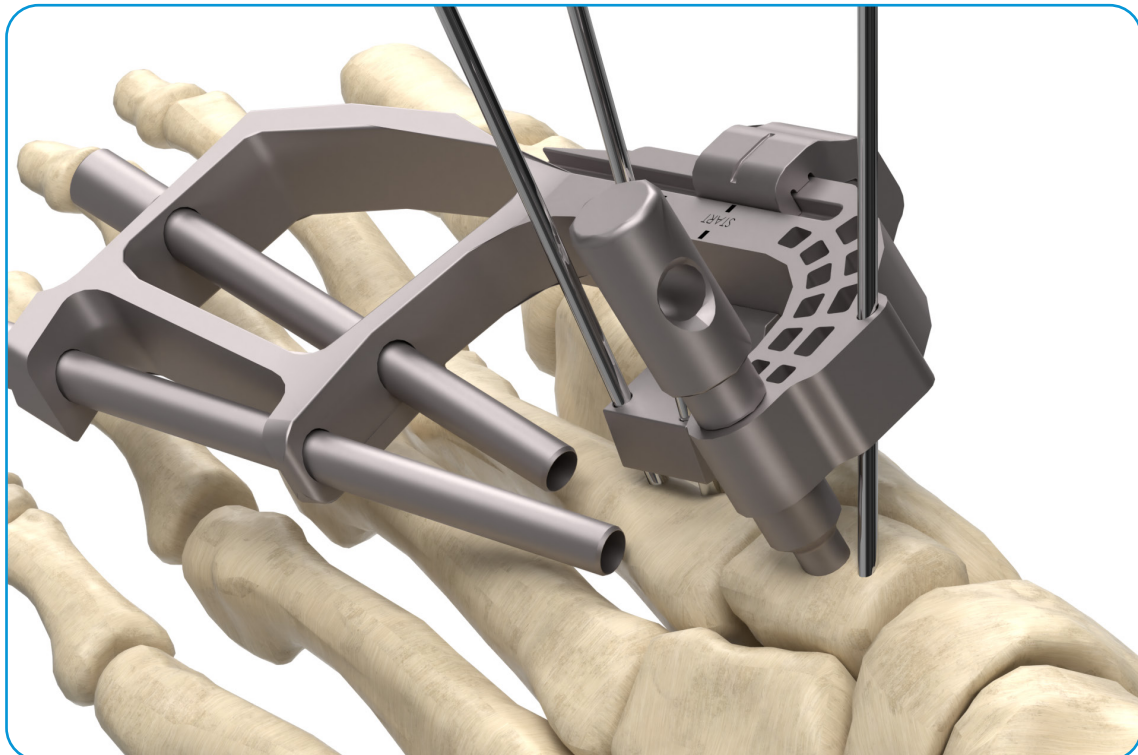

- 13.** Using the **T8 driver**, turn the **Screw** in the **Compression-Distraction Fixture** counter-clockwise to distract the tarsometatarsal joint.

NOTE: Soft tissue release may be required to achieve desired distraction and optimal visualization.

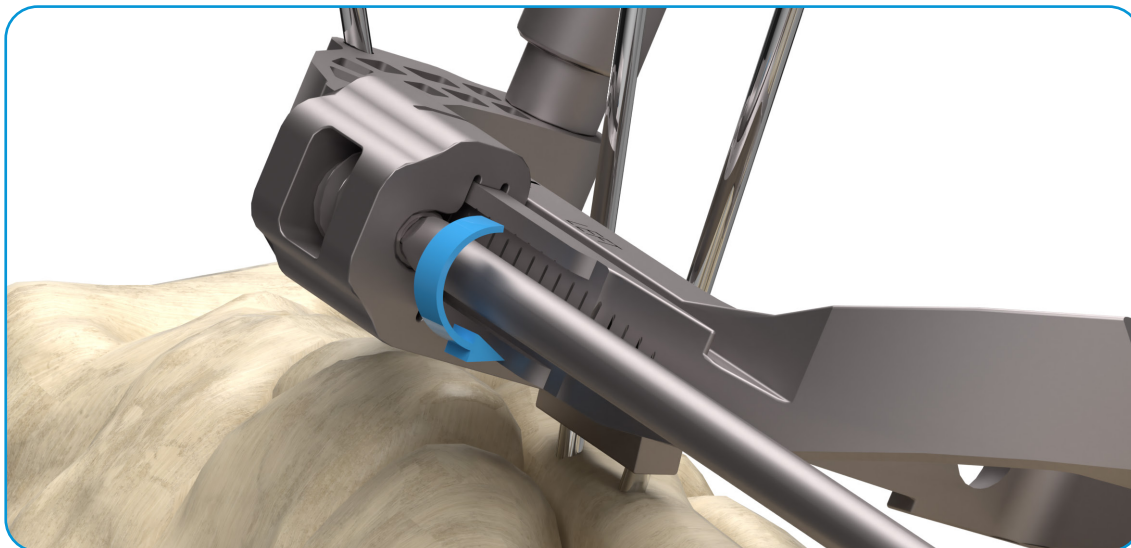

- 14.** After desired distraction is achieved, continue to prepare the joint with curettage, microfracture, and other preferred bone preparation methods.

NOTE: If performing this procedure on both 2nd and 3rd TMT joints, consider preparing both joints at the same time while the 2nd TMT joint is distracted.

- 15.** Following bone preparation, turn the **Screw** clockwise to compress the metatarsal to the cuneiform. While compressing, ensure metatarsal base does not deflect plantarly and that the **Post** does not shift dorsally.

NOTE: The metatarsal position should be assessed clinically and with intraoperative fluoroscopy or radiographs to ensure the desired position is achieved. If adjustment is necessary, remove compression, readjust the metatarsal position and K-wires as needed before recompressing the joint. Reassess screw trajectory by placing both bushings into the guide and confirm the anticipated trajectory will capture adequate bone.

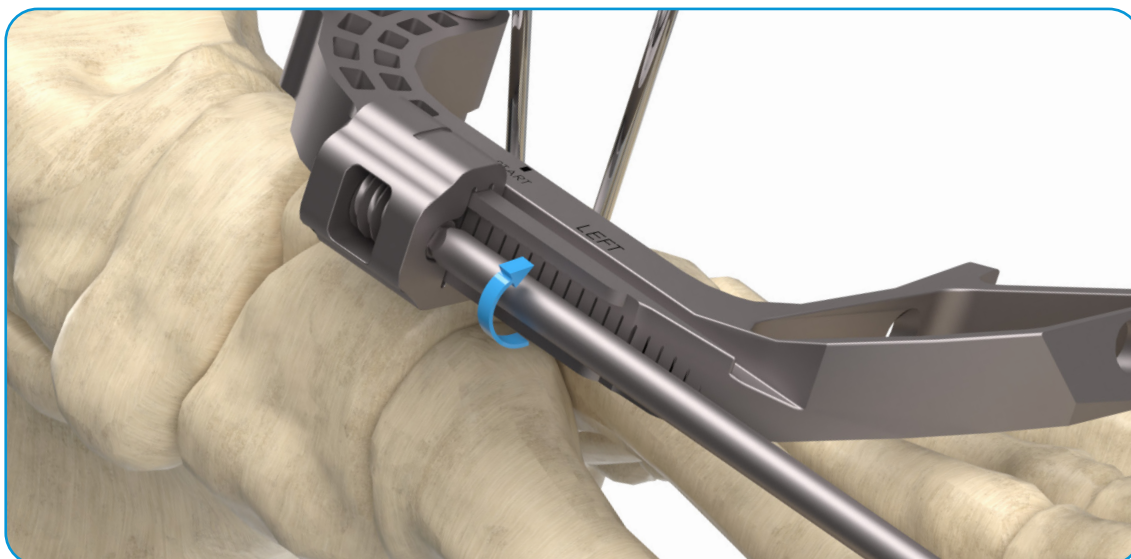

- 16.** Once desired position is achieved and secured in compression, place the **Implant Bushing** into the medial hole in the **Targeting Guide**. Ensure the **Implant Bushing** chosen is the longest bushing that will fully seat against the **Targeting Guide** without touching the metatarsal. Once the **Implant Bushing** is in place, insert the matching **Drill Bushing** into the **Implant Bushing**.

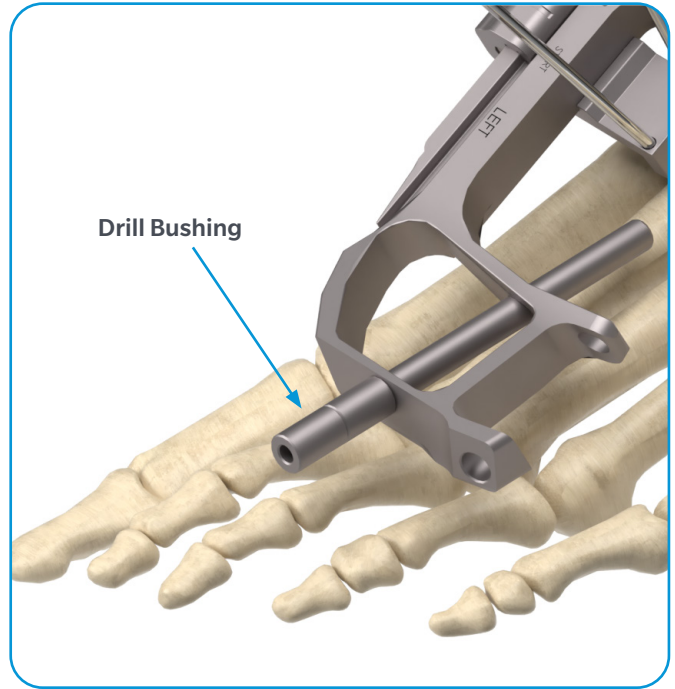
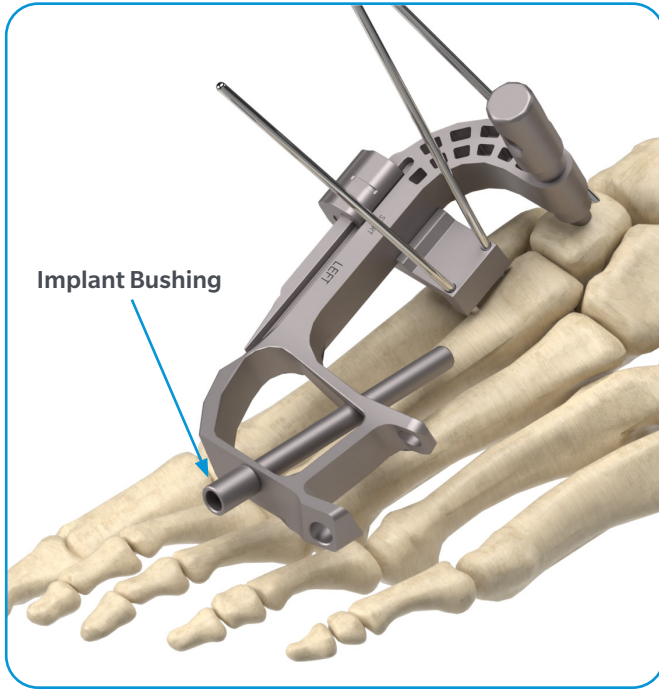

- 17.** Ensure the post is fully seated, then introduce the **2.8mm Drill Bit** into the **Drill Bushing**. **Do NOT begin drilling until the Drill Bit engages the bone. Peck drill as needed to prevent skyving.** Fully seat the **2.8mm Drill Bit** against the **Drill Bushing** (up to the step on the bit) to ensure drill creates a continuous tunnel of an appropriate length to the **Post**.

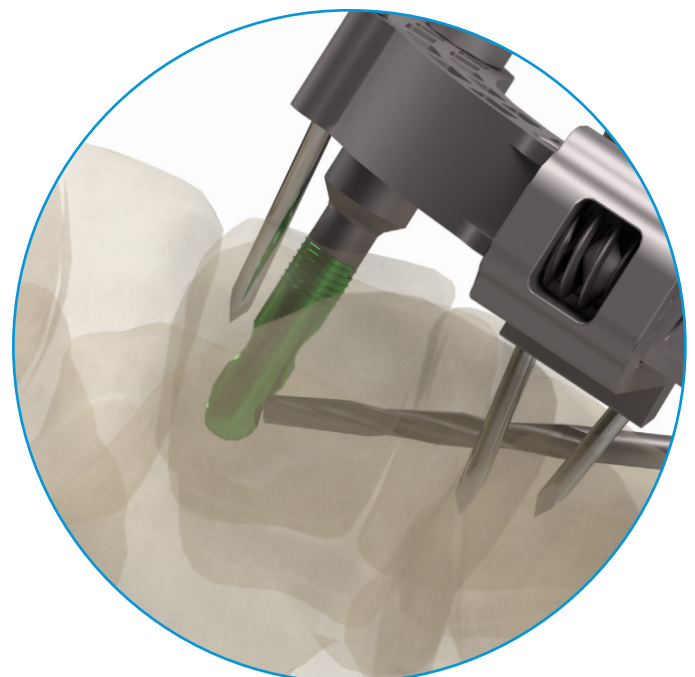
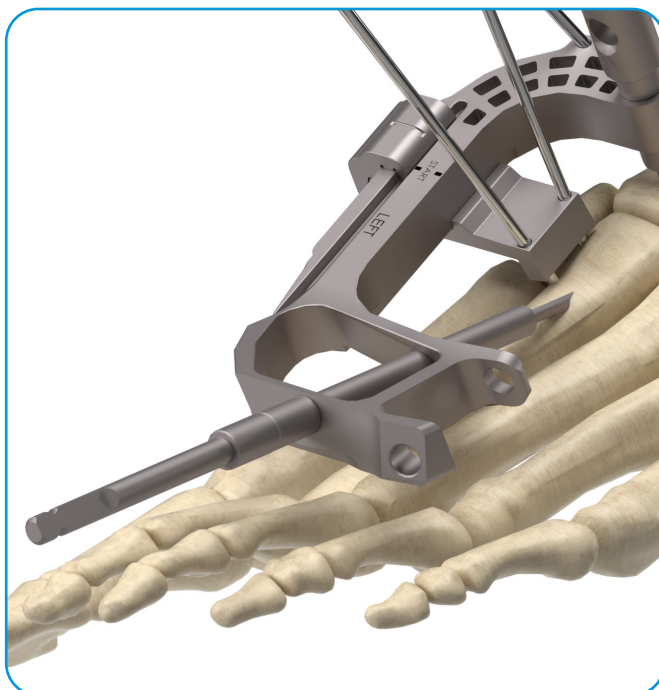

- 18.** Remove the **Drill Bushing** and place the **Depth Measuring Probe** through the **Implant Bushing** until the **Probe** makes firm contact with bone. It may be necessary to remove bone debris that could impede measurement. Then read the measurement at the guide surface which correlates with the suggested **2.7mm Screw** length. Based on measurement, select the corresponding **2.7mm Screw**. If measurement is between sizes, consider a shorter screw option to ensure the screw is not too prominent.

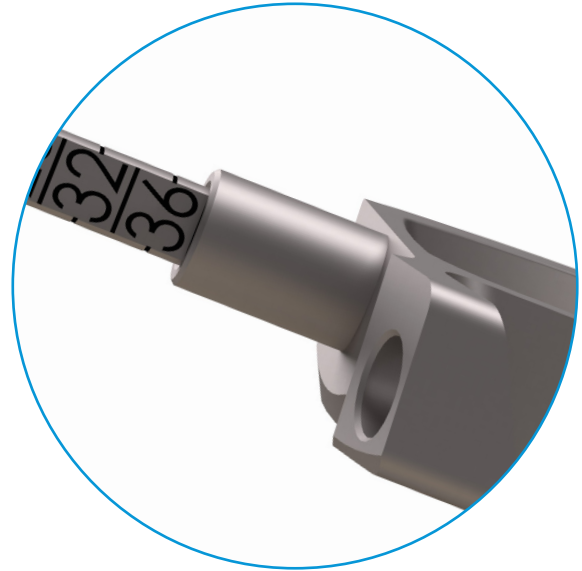

- 19.** Insert **2.7mm Screw** through pre-drilled tunnel until it reaches the **Post** and the rear screw head reaches the bone. Then rotationally advance until fully seated into the **Post**. Do NOT attempt to drive screw beyond hard stop. If screw head is too prominent or buried too deep, remove screw and select appropriate length.

NOTE: Care should be taken to ensure the 2.7mm Screw threads correctly into the Post without cross threading. Significant resistance prior to 5 full rotations is a sign of misalignment or cross threading.

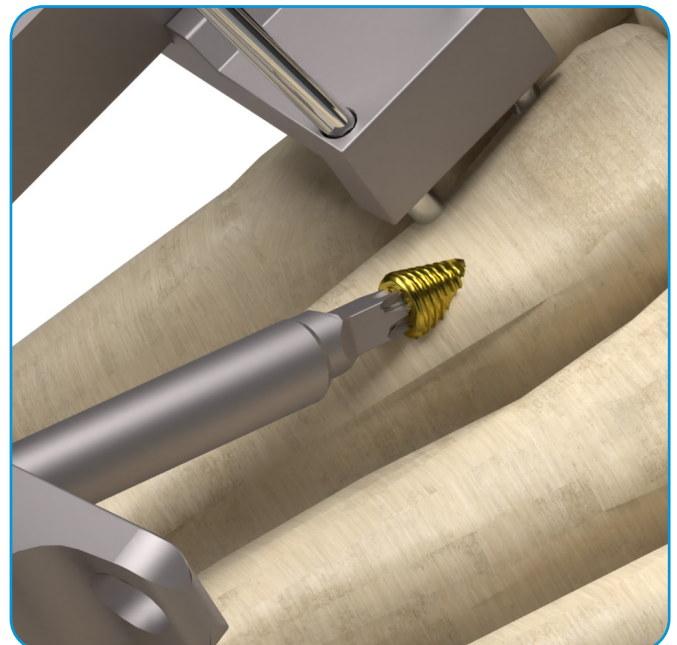
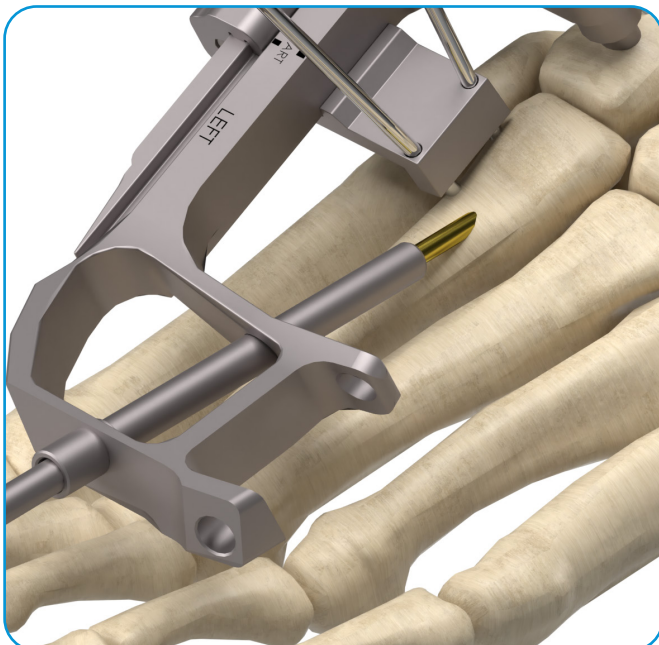

- 20.** Repeat the process of choosing the correct **Implant Bushing** and **Drill Bushing**, drilling, measuring for **2.7mm Screw** length, and screw placement for the lateral screw.

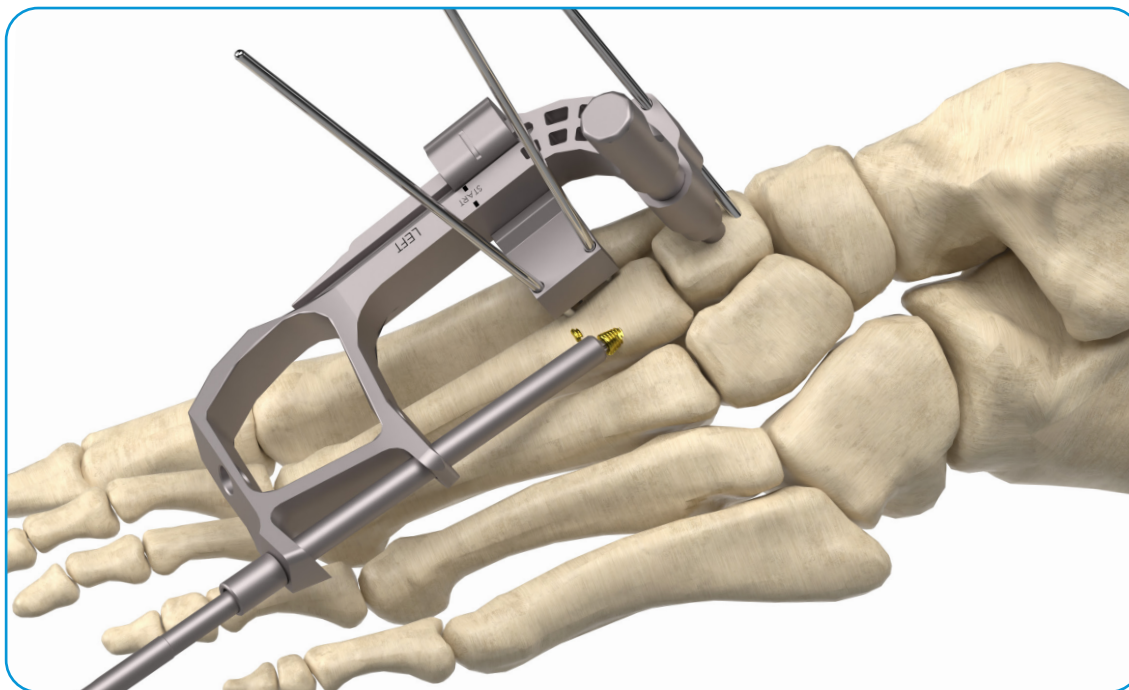

- 21.** To aid in removing **K-Wires**, slightly reduce the compression by turning **Compression-Distraction Fixture Screw** counter-clockwise and remove all **K-wires**. Twist **Post Fastener** to release from **Post** and remove **Targeting Guide**.

- 22.** Once both **2.7mm Screws** are locked into the **Post**, thread the **Post Plug Screw** into the top of the **Post**.

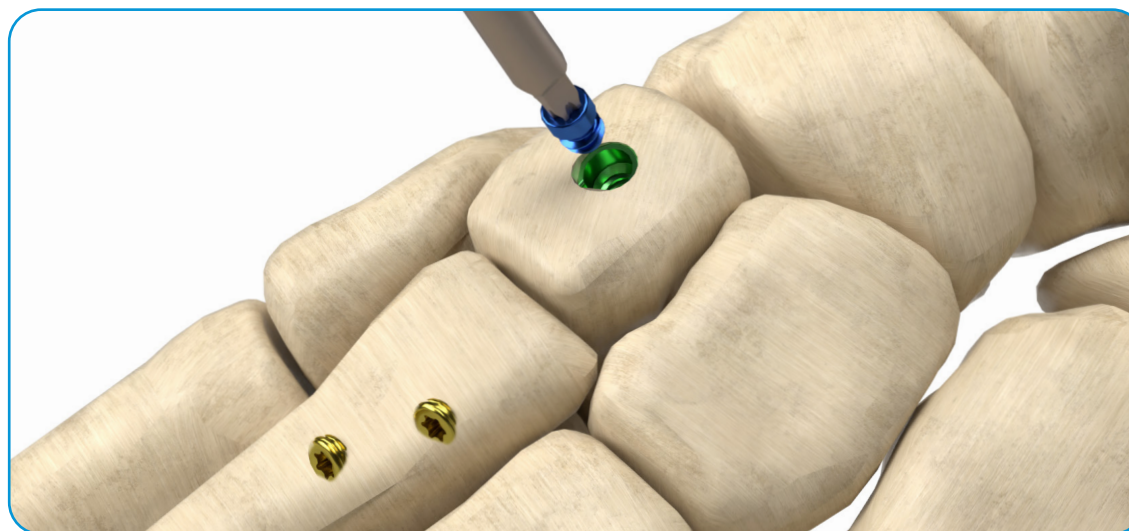

- 23.** Close in the usual manner.

Revision Surgical Technique

1. Make a dorsal incision over the tarsometatarsal joint.
2. Locate the **Post** in the cuneiform and clear bone to gain access.
3. Remove the **Post Plug Screw** using the **T8 Driver**.
4. Locate the **2.7mm Screws** in the metatarsal and clear bone to gain access.
5. Remove both **2.7mm Screws** using the **T8 Driver**.

NOTE: Reattaching Targeting Guide to post can aid in locating 2.7mm screws in metatarsal.

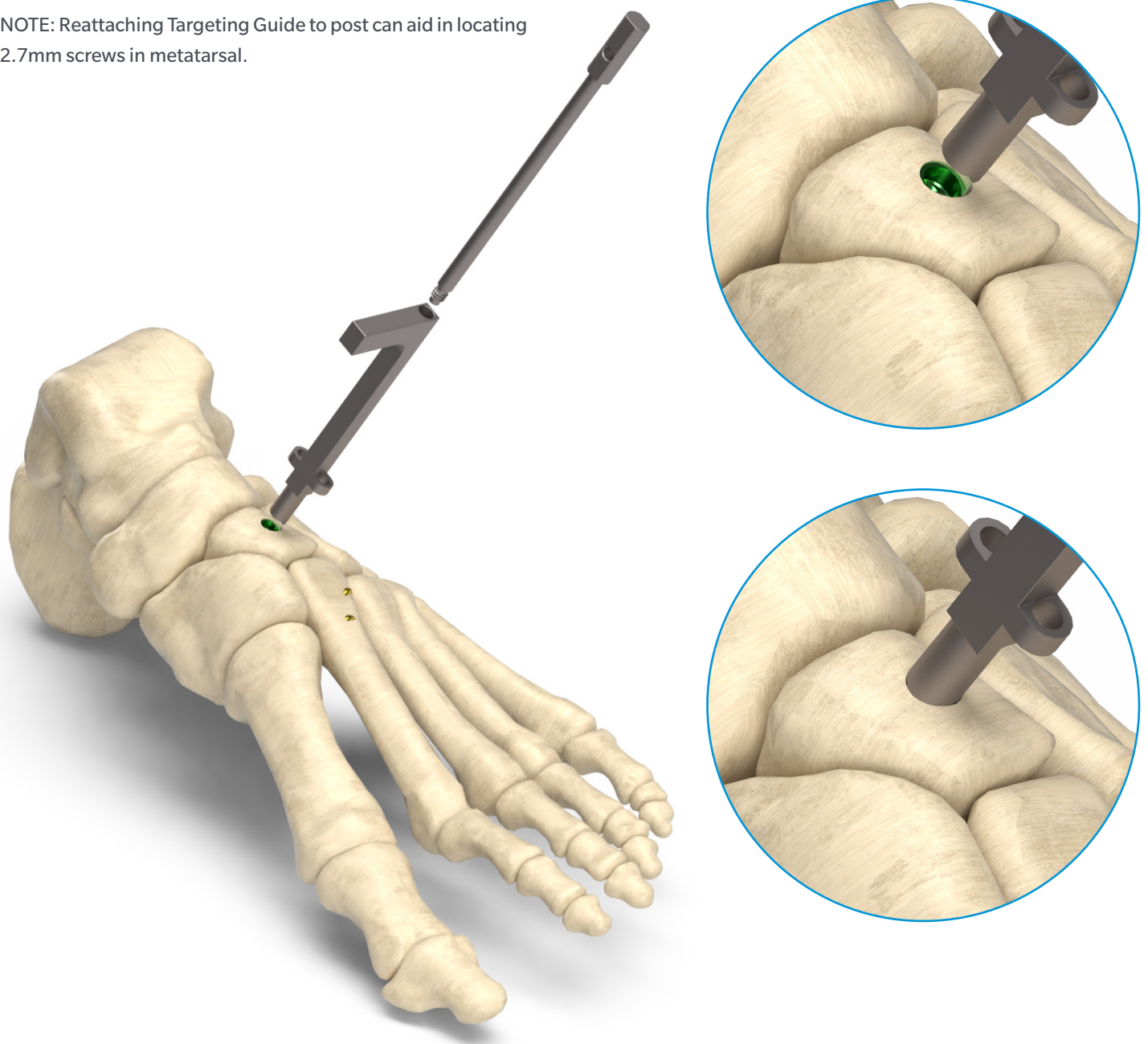

6. Align the **Revision Guide** with the **Post**. Place the **Revision Post Fastener** through the **Revision Guide** and thread onto the **Post**. Hand tighten to stabilize the assembly.
7. Review of removed screws and X-ray will indicate the presence of potential screw fragments. Long screw fragments should be removed using a standard screw removal system. If one or both screws have broken, leaving a small portion of the screw locked into the **Post**, run the **2.8mm Drill** through the guided hole on the side of the **Revision Guide** parallel to the **Post** until the screw fragment is reached.

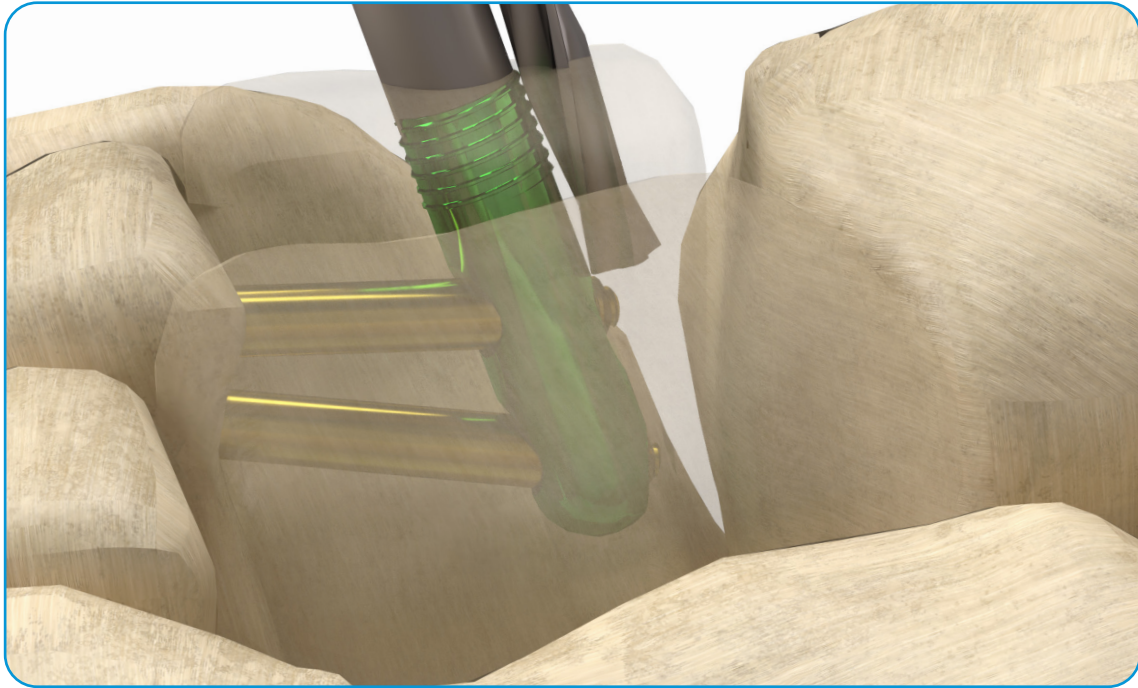

8. The **Revision Guide** can then be impacted dorsally to remove the **Post**.
9. If additional in-line force is required, the **Slap Hammer** can be attached by removing the **Revision Guide**, sliding the **Revision Post Fastener** through the **Slap Hammer** and reengaging with the **Post**.

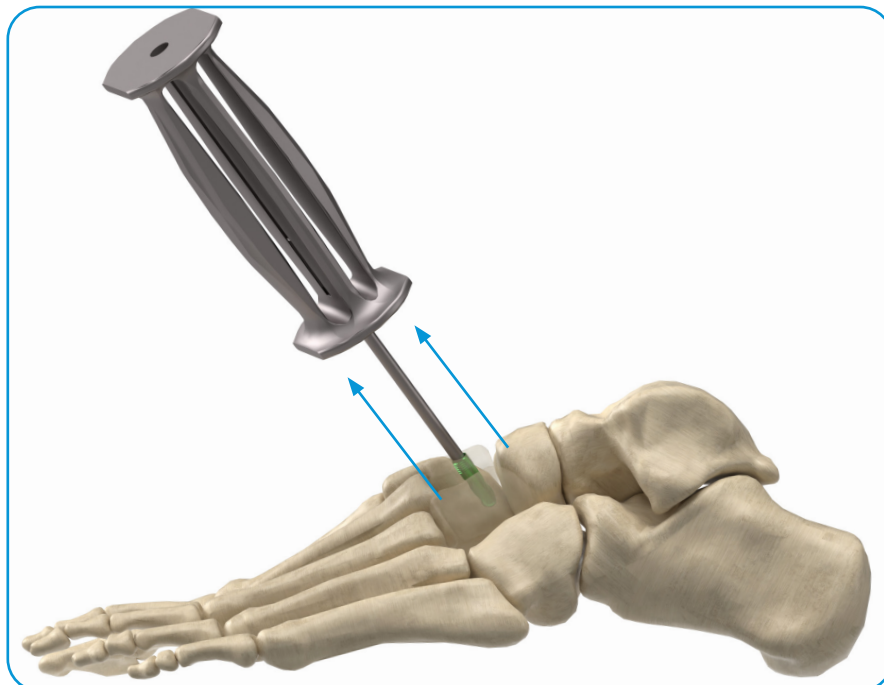

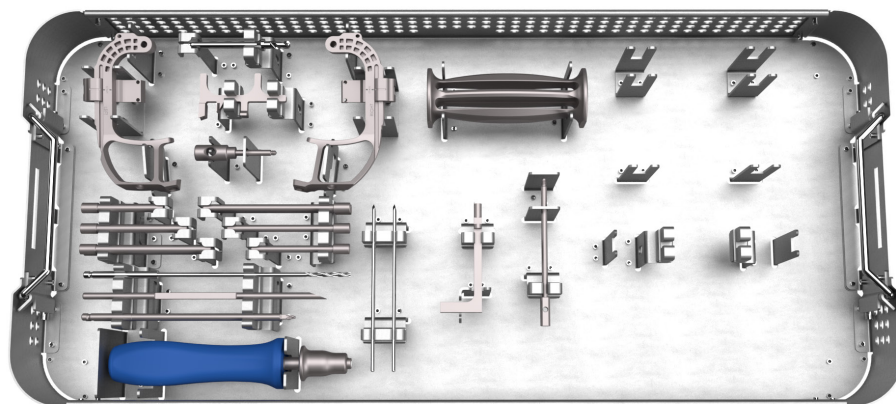

IMPLANTS

Part No.	Description
IC-TMT-4918RP	InCore TMT 4.9mm x 18mm Right Titanium Post
IC-TMT-4918LP	InCore TMT 4.9mm x 18mm Left Titanium Post
IC-TMT-2716	InCore TMT 2.7mm x 16mm Titanium Screw
IC-TMT-2720	InCore TMT 2.7mm x 20mm Titanium Screw
IC-TMT-2722	InCore TMT 2.7mm x 22mm Titanium Screw
IC-TMT-2724	InCore TMT 2.7mm x 24mm Titanium Screw
IC-TMT-2726	InCore TMT 2.7mm x 26mm Titanium Screw
IC-TMT-2728	InCore TMT 2.7mm x 28mm Titanium Screw
IC-TMT-2730	InCore TMT 2.7mm x 30mm Titanium Screw
IC-TMT-2732	InCore TMT 2.7mm x 32mm Titanium Screw
IC-TMT-2734	InCore TMT 2.7mm x 34mm Titanium Screw
IC-TMT-2736	InCore TMT 2.7mm x 36mm Titanium Screw
IC-TMT-2738	InCore TMT 2.7mm x 38mm Titanium Screw
IC-TMT-2740	InCore TMT 2.7mm x 40mm Titanium Screw
IC-TMT-2742	InCore TMT 2.7mm x 42mm Titanium Screw
IC-TMT-2744	InCore TMT 2.7mm x 44mm Titanium Screw
IC-TMT-2746	InCore TMT 2.7mm x 46mm Titanium Screw
IC-TMT-2748	InCore TMT 2.7mm x 48mm Titanium Screw
IC-TMT-2750	InCore TMT 2.7mm x 50mm Titanium Screw
IC-TMT-2752	InCore TMT 2.7mm x 52mm Titanium Screw
IC-TMT-27P	InCore TMT 4.9mm Post Plug Screw

INSTRUMENTS

Part No.	Description
IC-TMT-0000	InCore TMT Post Guide Reusable
IC-TMT-0101L	InCore TMT Targeting Guide Assembly Left Reusable
IC-TMT-0001R	InCore TMT Targeting Guide Assembly Right Reusable
IC-TMT-0107	InCore TMT Drill Bushing 40mm Reusable
IC-TMT-0108	InCore TMT Drill Bushing 55mm Reusable
IC-TMT-0109	InCore TMT Drill Bushing 70mm Reusable
IC-TMT-0127	InCore TMT Implant Bushing 40mm Reusable
IC-TMT-0128	InCore TMT Implant Bushing 55mm Reusable
IC-TMT-0129	InCore TMT Implant Bushing 70mm Reusable
IC-TMT-0112	InCore TMT Post Fastener Reusable
IC-TMT-0114	InCore TMT 4.9mm Post Drill Reusable
IC-TMT-0115	InCore TMT T8 Driver Reusable
IC-TMT-0116	InCore TMT 2.8mm Drill Bit Reusable
IC-TMT-0117	InCore TMT Removal Drill Guide Reusable
IC-LAP-0118	InCore Lapidus Removal Slap Hammer*
IC-TMT-0119	InCore TMT Removal Fastener Reusable
IC-TMT-0120	InCore TMT Depth Probe Reusable
IC-TMT-0131	InCore TMT Torque Limiting Handle Reusable
IC-TMT-0122	InCore TMT Instrument Case
IC-TMT-0123	InCore TMT Instrument Case Lid
IC-TMT-0104	InCore TMT Replacement Compression Frame
IC-TMT-0105	InCore TMT Replacement Compression Screw
NSI-KW20	2.0mm x 4" K-Wire Sterile
IC-TMT-T8	InCore TMT T8 Driver Sterile
IC-TMT-D28	InCore TMT 2.8mm Drill Bit Sterile
IC-TMT-D49	InCore TMT 4.9mm Post Drill Sterile

*Must be purchased separately through Zimmer Biomet

INDICATIONS: InCore® TMT System is a three-part construct intended for internal fixation for Lesser Tarsometatarsal Joint Arthrodesis (also known as Lisfranc Joint Fusion or 2nd/3rd Tarsometatarsal Fusion).

CONTRAINDICATIONS: (1) Patient conditions including insufficient quantity or quality of bone. (2) Blood supply limitations and previous or active infections that may inhibit healing. (3) Surgical procedures other than for the indications listed. (4) Patients with conditions that limit their ability or willingness to follow postoperative care instructions. (5) The device may not be suitable for patients with insufficient or immature bone. The physician should carefully assess bone quality before performing orthopedic surgery on patients who are skeletally immature. (6) Where material sensitivity is suspected, appropriate testing should be performed and sensitivity ruled out prior to implantation. (7) The InCore TMT System requires placement of a titanium post in the second (intermediate) or third (lateral) cuneiform bone. For optimum fixation strength, the post should be fully encapsulated in bone. The device may be unsuitable for patients with small, thin, bifurcated, split, fractured, or otherwise abnormally shaped bone.

This material is intended for health care professionals. Distribution to any other recipient is prohibited. For product information, including indications, contraindications, warnings, precautions, potential adverse effects and patient counseling information, see the package insert. Check for country product clearances and reference product-specific instructions for use.

Zimmer Biomet does not practice medicine. This technique was developed in conjunction with health care professionals. This document is intended for surgeons and is not intended for laypersons. Each surgeon should exercise his or her own independent judgment in the diagnosis and treatment of an individual patient, and this information does not purport to replace the comprehensive training surgeons have received. As with all surgical procedures, the technique used in each case will depend on the surgeon's medical judgment as the best treatment for each patient. Results will vary based on health, weight, activity and other variables. Not all patients are candidates for this product and/or procedure. Caution: Federal (USA) law restricts this device to sale by or on the order of a surgeon. Rx only.

InCore is a trademark of Zimmer, Inc.

The InCore TMT System is manufactured using Ti 6-4 ELI.

©2023 Zimmer, Inc.

LIT-1568 Rev.06

 **ZIMMER BIOMET**
Your progress. Our promise.™

Distributed by:

Zimmer, Inc.
1800 West Center St.
Warsaw, IN 46580 U.S.A.
(800) 613-6131
contactus@zimmerbiomet.com

medartis

 Legal Manufacturer:

Medartis Inc.
1195 Polk Drive
Warsaw, IN 46582 USA
732-383-7901
medartisusa.com