

InCore® Subtalar Precision Guided Correction

Surgical Technique

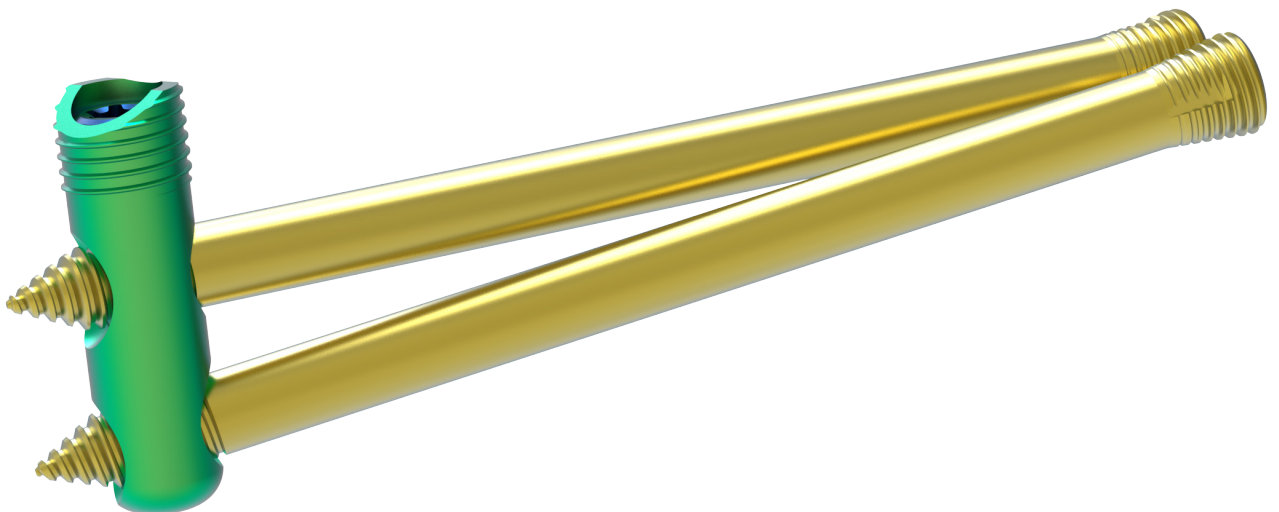

InCore Subtalar System

Precision Guided Correction

INTENDED USE:

The InCore® Subtalar System is intended for reduction and internal fixation of arthrodesis, osteotomies, and nonunions of the bones and joints of the foot. The three-part construct is specifically intended for internal fixation for Subtalar Joint Arthrodesis (also known as Subtalar Joint Fusion).

INDICATIONS:

The InCore® Subtalar System is intended for reduction and internal fixation of arthrodesis, osteotomies, and nonunions of the bones and joints of the foot. The three-part construct is specifically intended for internal fixation for Subtalar Joint Arthrodesis (also known as Subtalar Joint Fusion).

CONTRAINDICATIONS:

- Patient conditions including insufficient quantity or quality of bone.
- Blood supply limitations and previous or active infections that may inhibit healing.
- Surgical procedures other than for the indications listed.
- Patients with conditions that limit their ability or willingness to follow postoperative care instructions.
- The device may not be suitable for patients with insufficient or immature bone. The physician should carefully assess bone quality before performing orthopedic surgery on patients who are skeletally immature.
- Where material sensitivity is suspected, appropriate testing should be performed and sensitivity ruled out prior to implantation.
- The InCore Subtalar System requires placement of a titanium post in the talus. For optimum fixation strength, the post should be fully encapsulated in bone. The device may be unsuitable for patients with small, thin, bifurcated, split, fractured, or otherwise abnormally shaped bone.

InCore Subtalar System Precision Guided Correction

- **Fully Guided**

- Post and Targeting Guide utilize anatomical landmarks to facilitate fixation placement

- **Solid Intraosseous Construct**

- Solid 8.0mm Titanium Post provides large surface area engagement in the cancellous bone of the talus
- Headless compression screws thread directly into the 8.0mm post
- The post and screws construct is designed to fit in the bone to help minimize painful hardware prominence often reported with headed screws

- **Joint Preparation**

- Targeting Guide provides distraction of the joint for visualization and joint preparation
- Distraction allows space for curettage and microfracture

- **Controlled Compression**

- Targeting Guide includes built-in Compression-Distraction Fixture providing compression parallel to the long axis of the screws

- **Features**

- 8.0mm x 28mm Titanium Post
- 5.5mm Diameter Headless Compression Screws offered from 60 to 110mm in length
- Robust T25 Hexalobe Driver

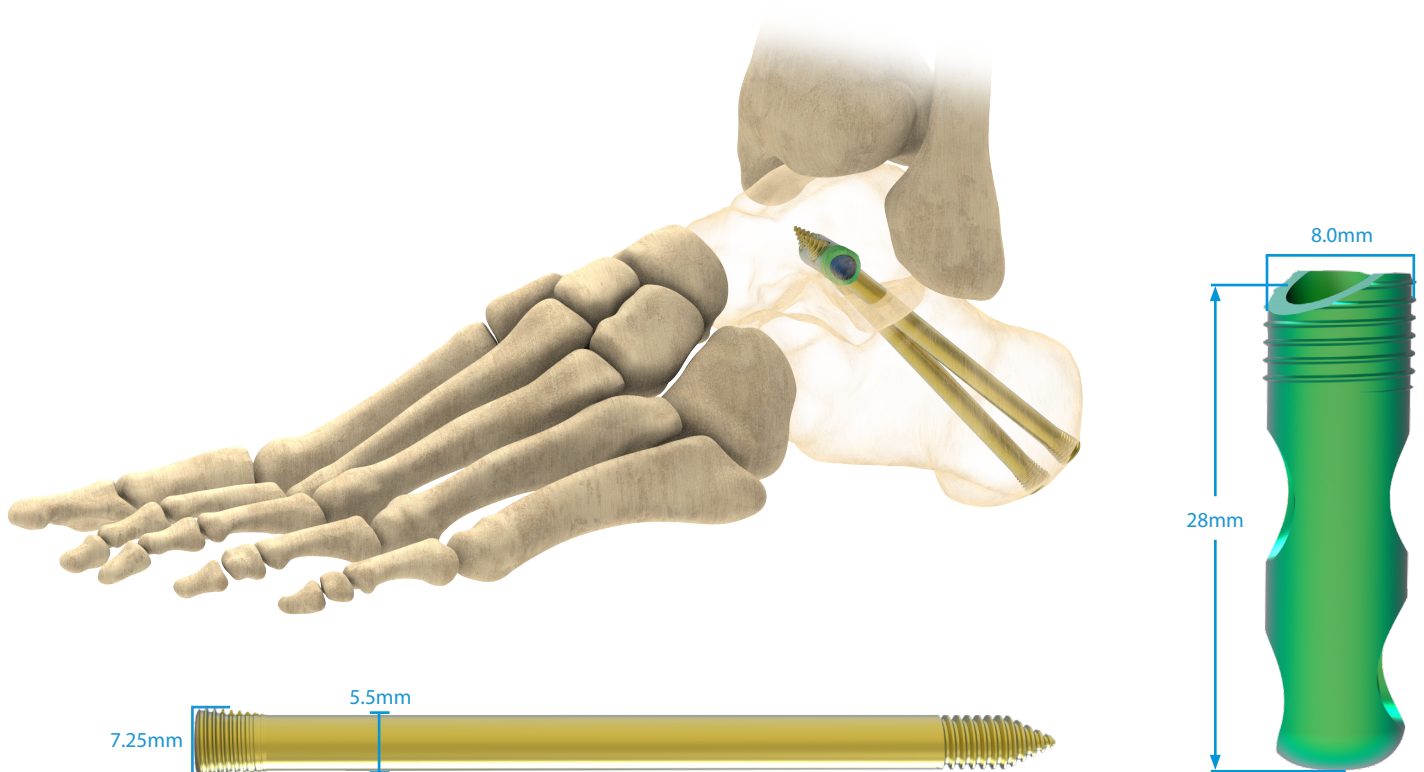

Surgical Technique

1. Prepare instrumentation by first ensuring the **Compression-Distraction Fixture** is aligned approximately 1/3 of the way from the end of the track of the **Targeting Guide**. The **T25 Driver** is used to rotate the **Screw**, causing the **Compression-Distraction Fixture** to travel along the **Targeting Guide**. Improper alignment of the fixture on the guide may restrict potential distraction and compression travel of the **Compression-Distraction Fixture**.

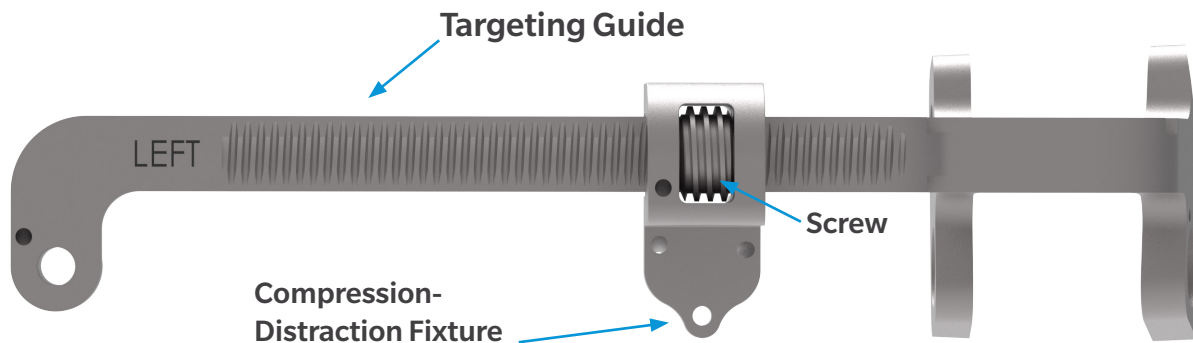

2. Assemble the **InCore Subtalar Post** to the **Targeting Guide**. Thread the **Post Fastener** into the implant **Post**, with the **Targeting Guide** positioned between. After firm hand tightening of the **Post Fastener**, there will be no gap or play between the components.

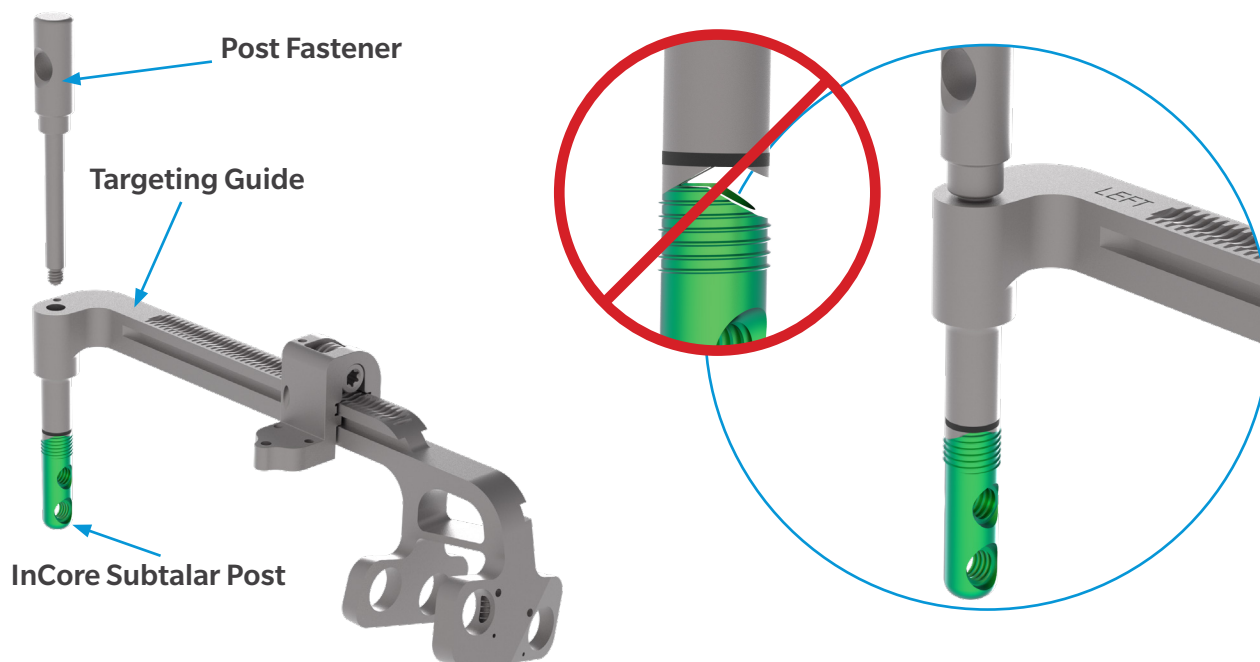

3. Sighting the holes in the **Targeting Guide**, alignment can be visualized to ensure proper assembly and left/right foot selection. The *plantar hole* of the **Targeting Guide** aligns with the *medial hole* in the **Post**. The *dorsal hole* of the **Targeting Guide** aligns with the *lateral hole* of the **Post**.

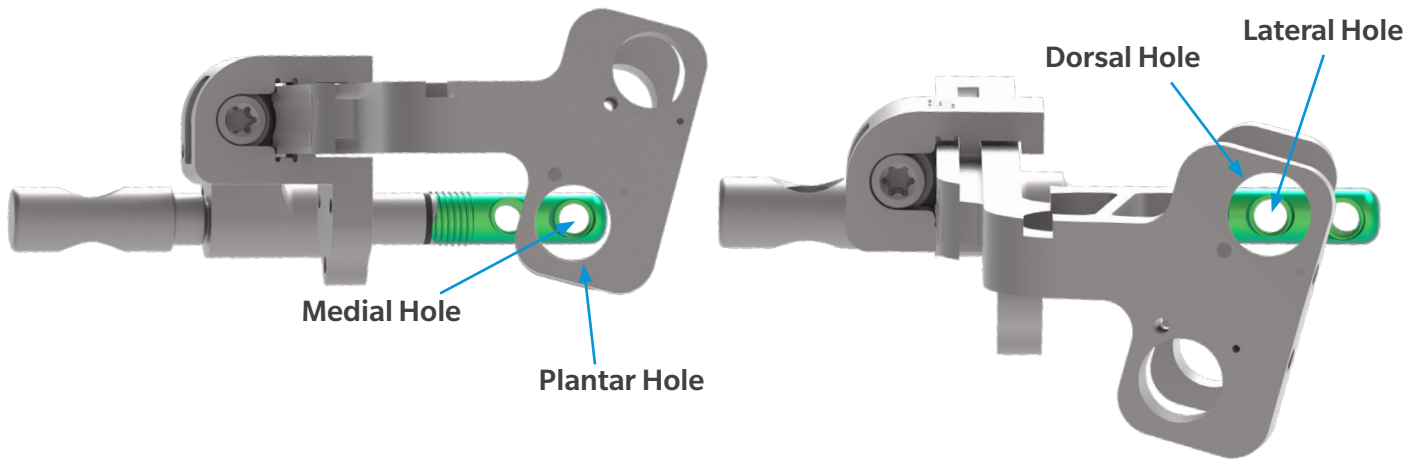

4. Make a sinus tarsi incision over the subtalar joint.
5. Perform soft tissue releases to ensure full mobility of the subtalar joint to the desired correction position.



6. Position the **Post Guide** so that the foot is on the talar neck/body intersection, the paddle is aligned with the subtalar joint line at the lateral process of the talus, and the targeting holes are aligned in the lateral third of the calcaneus.

NOTE: Marking lines along the skin on the heel to divide the calcaneus into thirds may help achieve proper placement.

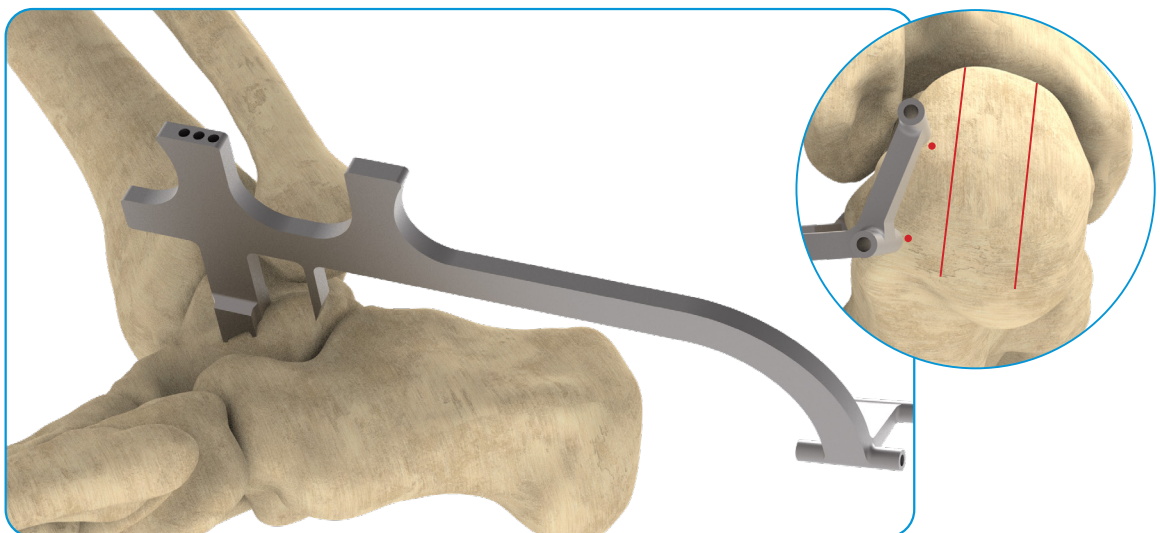

7. Place a **2mm x 4" K-wire** into the talus through the center hole of the **Post Guide**, and place the **2mm x 9" K-wires** through the targeting holes and into the calcaneus to evaluate implant positioning. Verify the screw trajectories to ensure the screws will not break out of the calcaneus laterally or medially. Ensure entry location is dorsal to the weightbearing surface and plantar to the Achilles tendon. Adjust the **K-wire** and **Post Guide** placement as necessary to achieve optimal implant positioning.

NOTE: The location of the **K-wire** should be assessed to ensure the **K-wire** is surrounded by adequate bone for reaming. Utilize AP, lateral, and calcaneal axial X-rays to evaluate projected implant placement. There must be at least 28mm of tunnel to ensure the post is appropriately seated in the bone. Adjust the **K-wire** when necessary to account for variations in anatomy. If moving the **K-wire** location, re-evaluate the anticipated screw trajectories by placing the **Post Guide** over the **K-wire** through the center hole and replacing **K-wires** through the targeting holes.

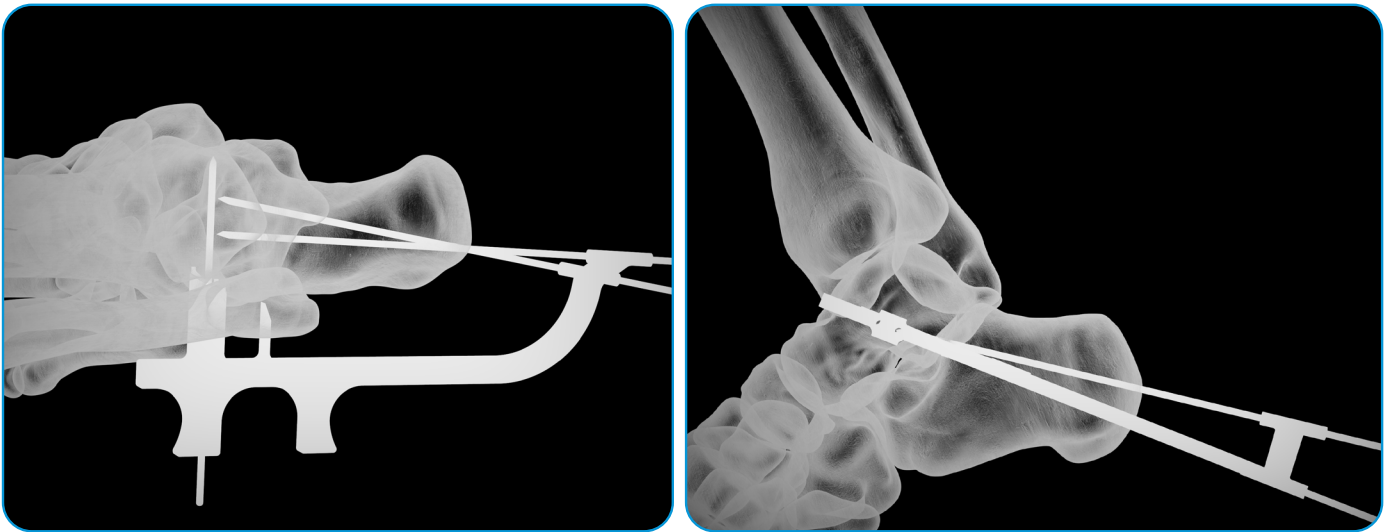

Simulated X-Ray Images

8. Mark a line on the skin along the **Post Guide** arm for future reference with **Targeting Guide** alignment.

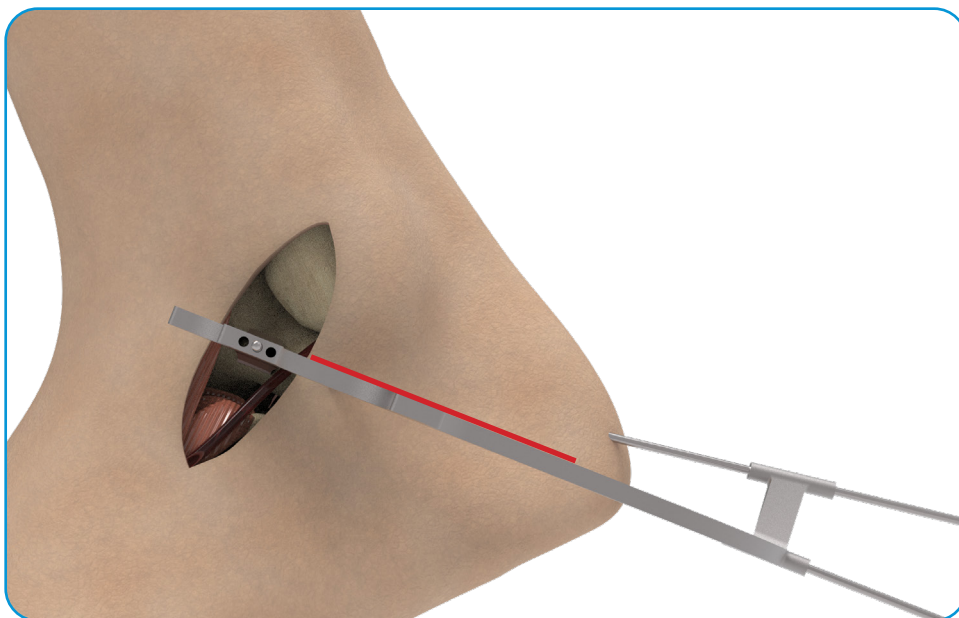

9. Remove the **2mm x 9" K-wires** and **Post Guide**, leaving the **2mm x 4" K-wire** in the talus. Before drilling, place the **8.0mm Post Drill** over the **K-wire** to ensure post location is appropriate with adequate surrounding bone. Utilize a lateral X-ray to verify.

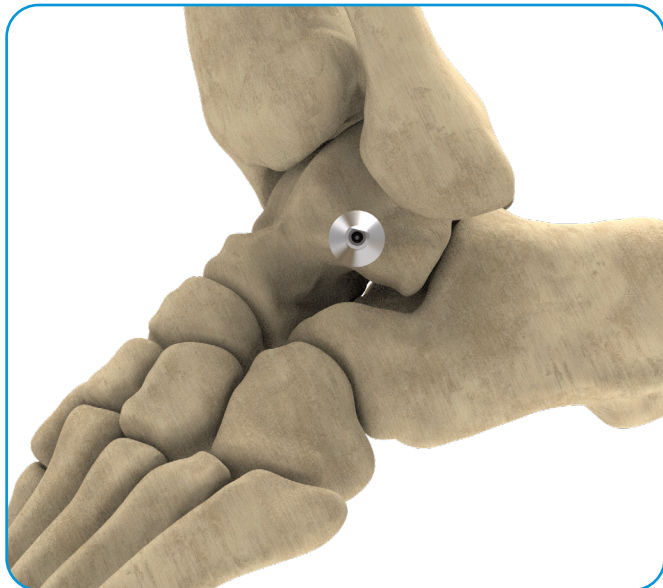

Simulated X-Ray Image

10. Insert the **8.0mm Post Drill** over the **2mm x 4" K-wire** and drill until the depth line on the drill bit is at or just below bone surface, or to hard stop.

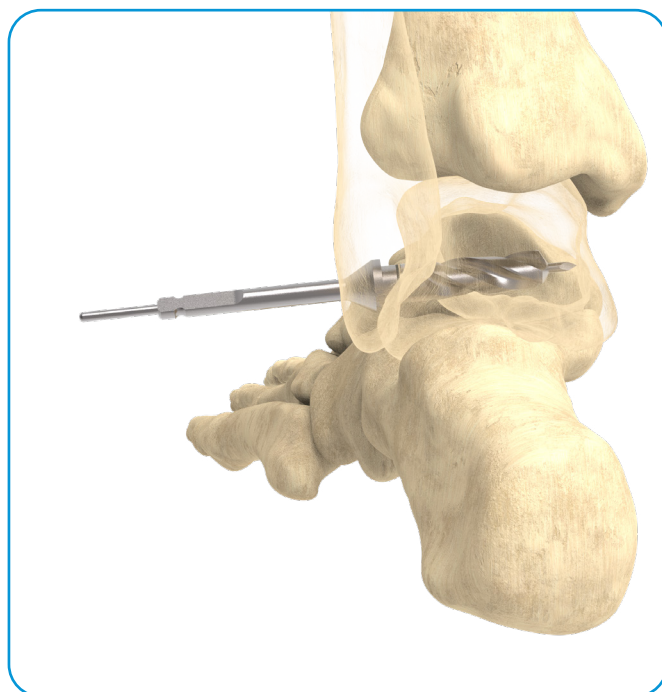
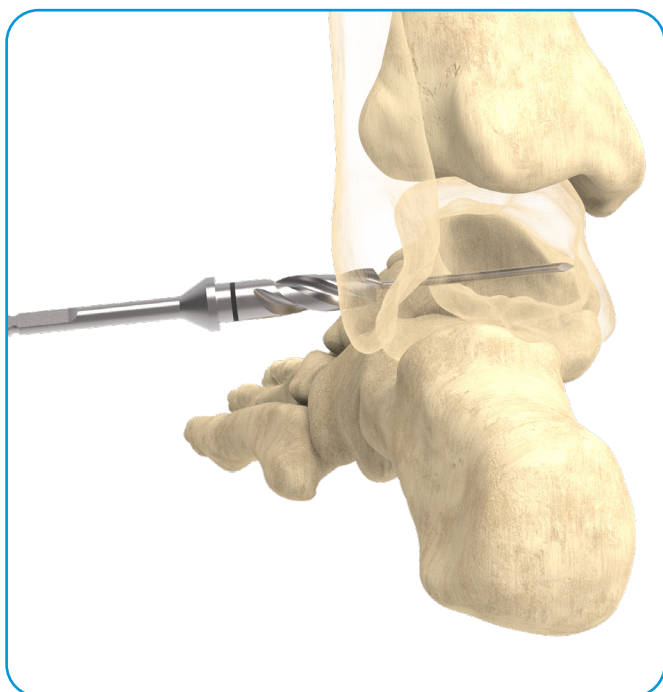

11. Insert the **Post** and **Targeting Guide Assembly** into the hole located in the talus. Fully seat the **Post** into the bone ensuring the **Targeting Guide** depth lines are at or just below bone surface.

NOTE: Light malleting may be required to fully seat post.

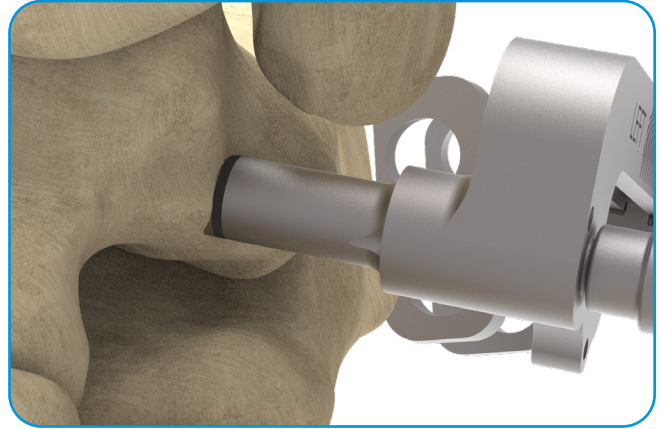
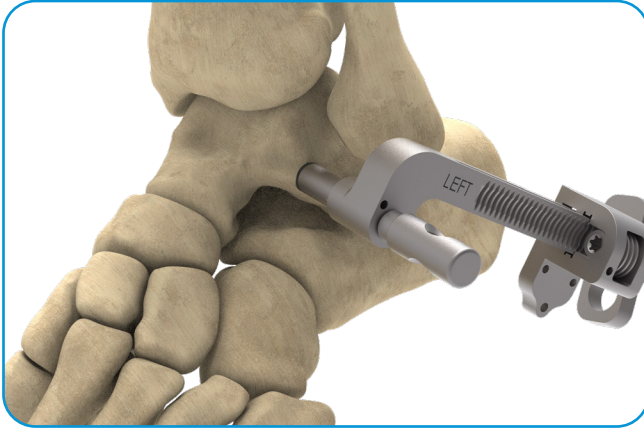

12. Manipulate the calcaneus to achieve desired positioning.

Align the **Targeting Guide** track parallel to the line previously drawn on the skin from the **Post Guide**. Move the **Compression-Distraction Fixture** such that the **K-wires** will be placed at the distal aspect of the calcaneus percutaneously. Evaluate the anticipated screw entry points on the calcaneus. Screws should enter in the lateral third of the calcaneus and between the weight bearing surface of the calcaneus and the Achilles tendon. Proper depth of the **Post** and rotation of the **Targeting Guide** about the **Post** are elements that can affect the entry point of screws in the calcaneus.

Once the calcaneus and **Targeting Guide** are positioned in the desired location, place two **2mm x 4"** **K-wires** through the **Compression-Distraction Fixture** and into the calcaneus to stabilize positioning. When inserting the **2mm x 4"** **K-wires**, check to ensure they are clear of the peroneal tendon.

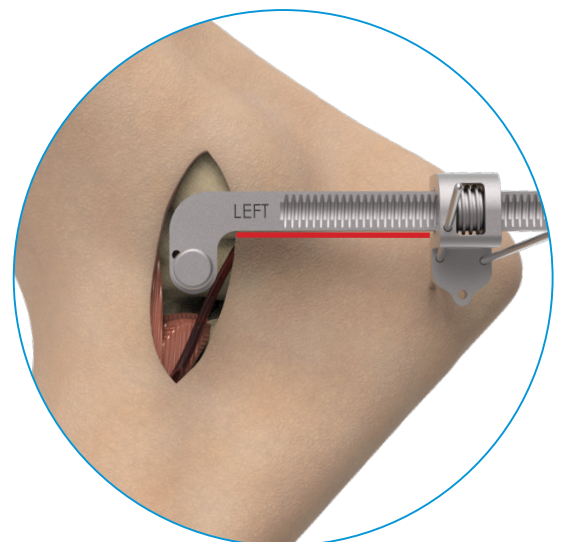
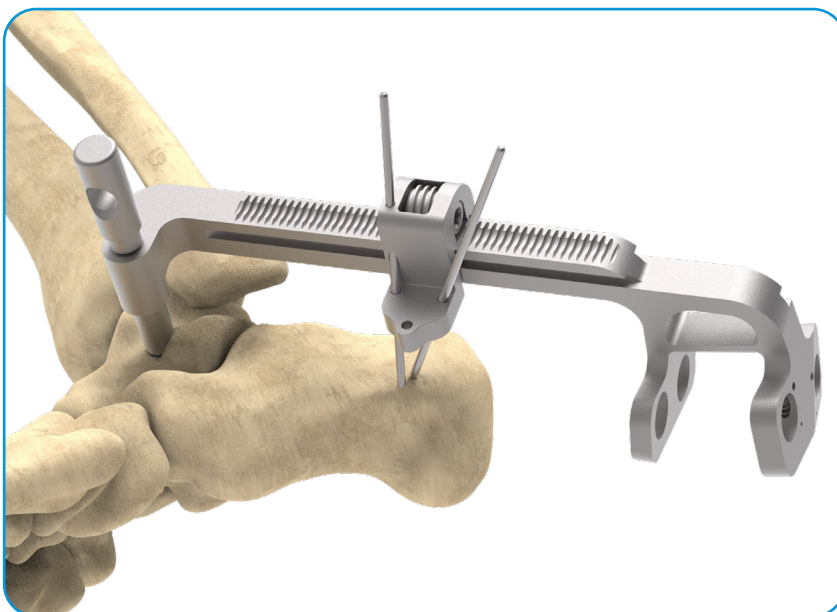

- 13.** In soft bone, a **2.4mm x 4" K-wire** may be placed through the distal hole in the **Compression-Distractor Fixture** into the calcaneus for added fixation. An additional **2mm x 4" K-wire** may be placed proximal to the **Post** to secure rotation of the **Targeting Guide** as well as depth of the **Post**, as necessary.

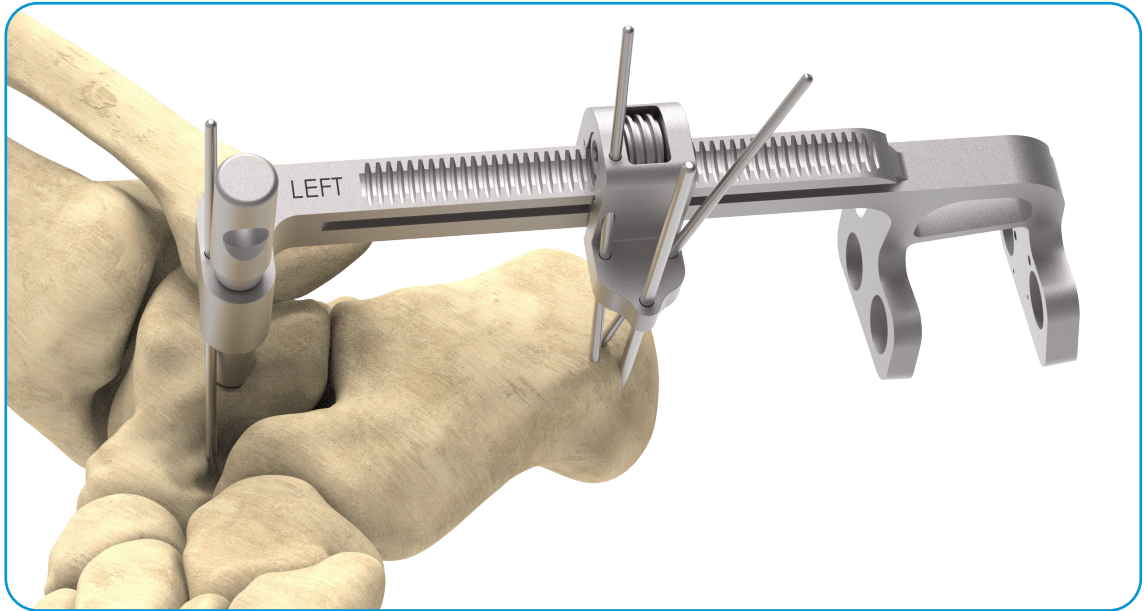

- 14.** Using the **T25 Driver**, turn the **Compression Screw** in the **Compression-Distractor Fixture** counter-clockwise to distract the subtalar joint.

NOTE: Soft tissue release may be required to achieve desired distraction and optimal visualization. To ensure linear distraction and compression, make sure the distractor is perpendicular to the subtalar joint.

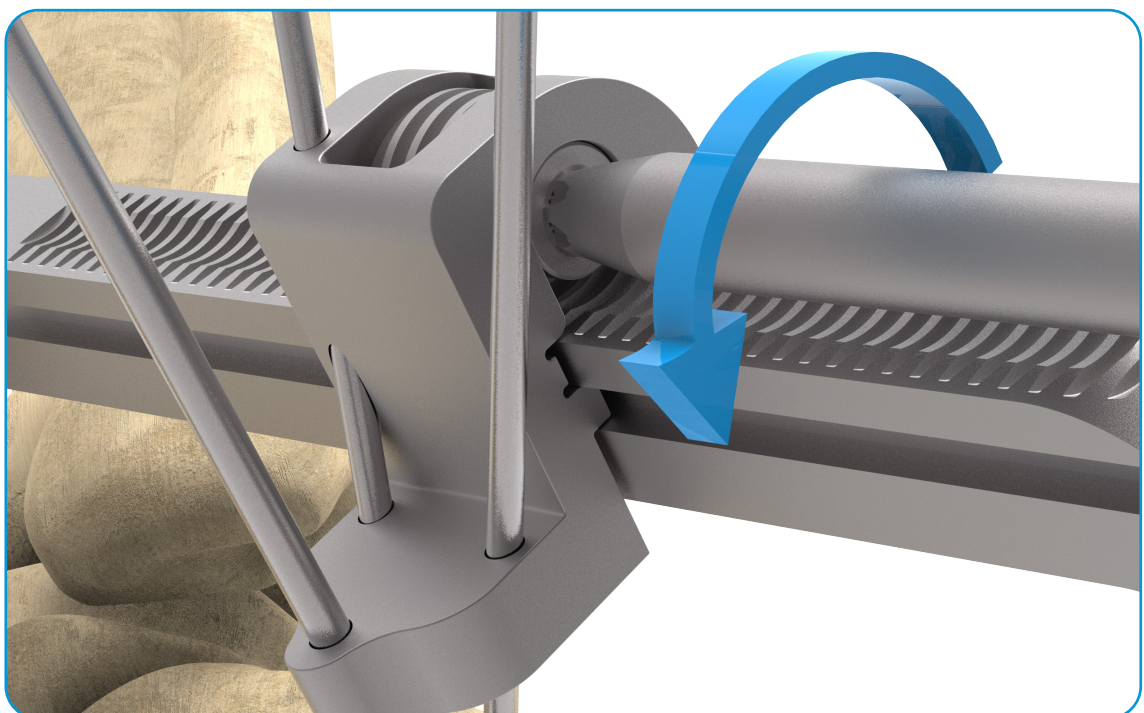

15. After desired distraction is achieved, continue to prep the joint with curettage, microfracture, and other preferred bone preparation methods.

16. Following bone preparation, turn the **Compression Screw** clockwise to compress the calcaneus to the talus.

NOTE: The calcaneus position should be assessed clinically and with intraoperative fluoroscopy or radiographs to ensure the desired position is achieved. If adjustment is necessary, remove compression, readjust the calcaneus position and K-wires as needed before recompressing the joint. Reassess screw trajectory and confirm the anticipated trajectory will capture adequate bone.

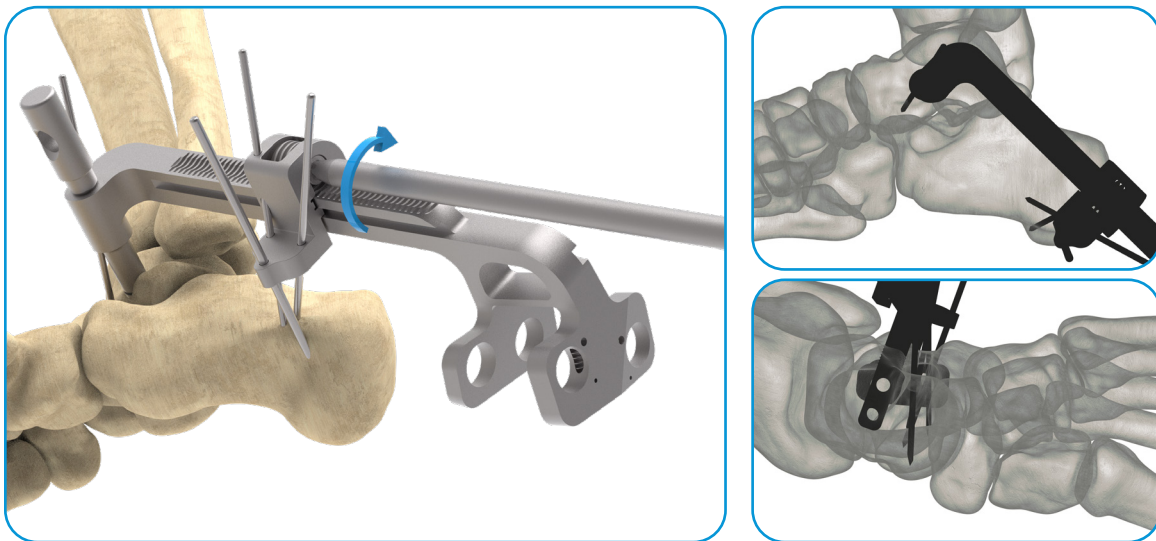

Simulated Fluoroscopic Images

17. Once desired positioning is achieved and secured in compression, place the **Drill Bushing** into the plantar hole in the **Targeting Guide**. Ensure the **Drill Bushing** chosen is the longest bushing that will fully seat against the **Targeting Guide**.

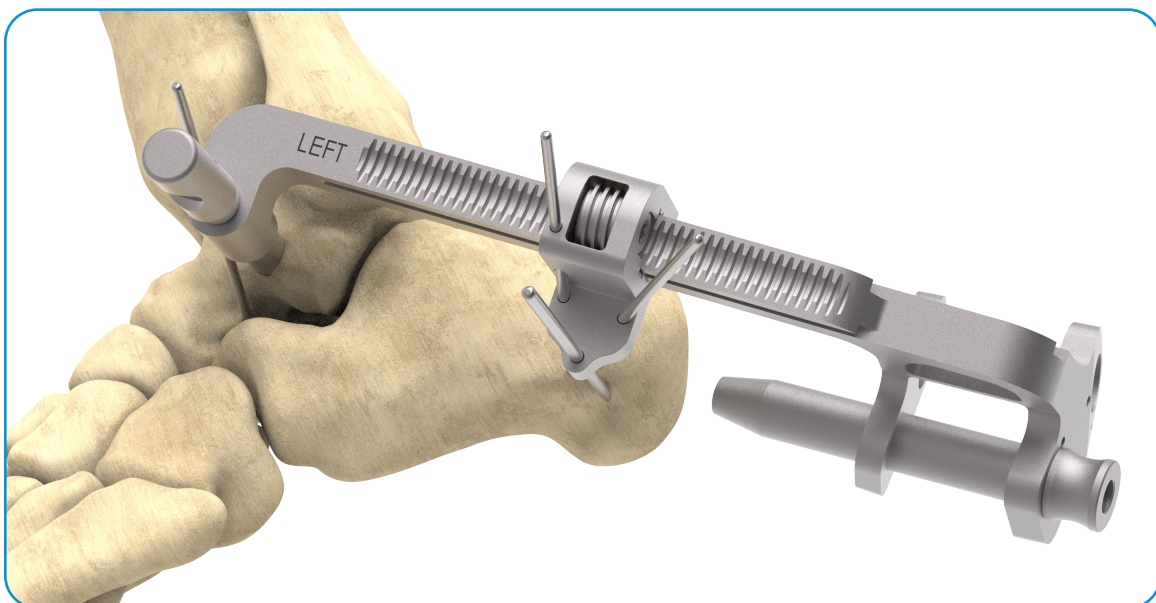

- 18.** Ensure the **Post** is fully seated into the talus. Introduce the **5.6mm Drill Bit** into the **Drill Bushing**. Do NOT begin drilling until the **Drill Bit** engages the bone. Peck drill as needed to prevent skyving. Fully seat the **5.6mm Drill Bit** against the **Drill Bushing** (up to the step on the bit) to ensure drill creates a continuous tunnel of an appropriate length to the **Post**.

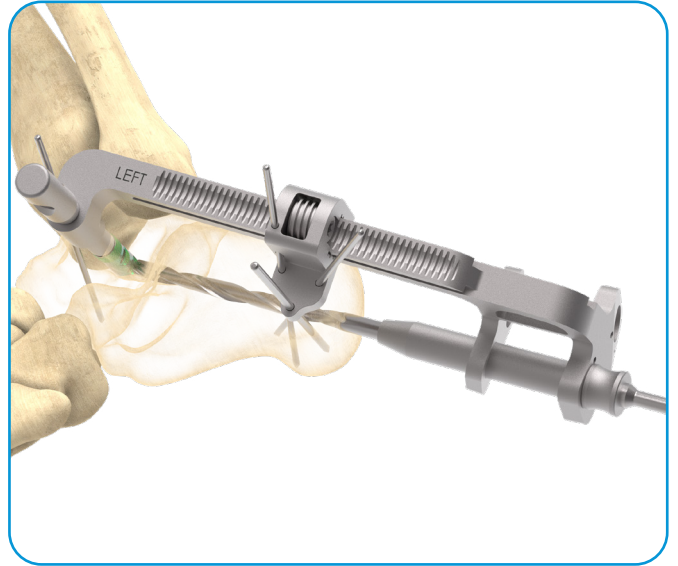
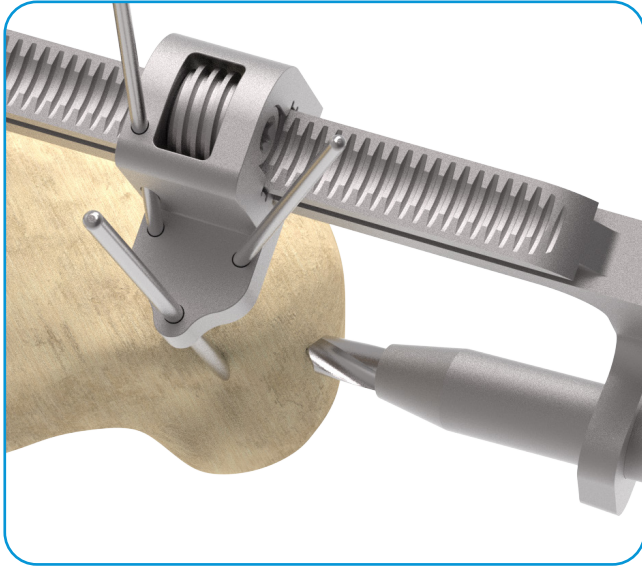

- 19.** Remove the **Drill Bushing** and insert the **Implant Bushing**. Place the **Depth Measuring Probe** through the **Implant Bushing** until the **Probe** makes firm contact to bone. It may be necessary to remove bone debris that could impede measurement. Read the measurement at the guide surface which correlates with the suggested **5.5mm Screw** length. Based on the measurement, select the appropriate **5.5mm Screw** length. If measurement is between sizes, consider a shorter screw option to ensure the screw is not too prominent.

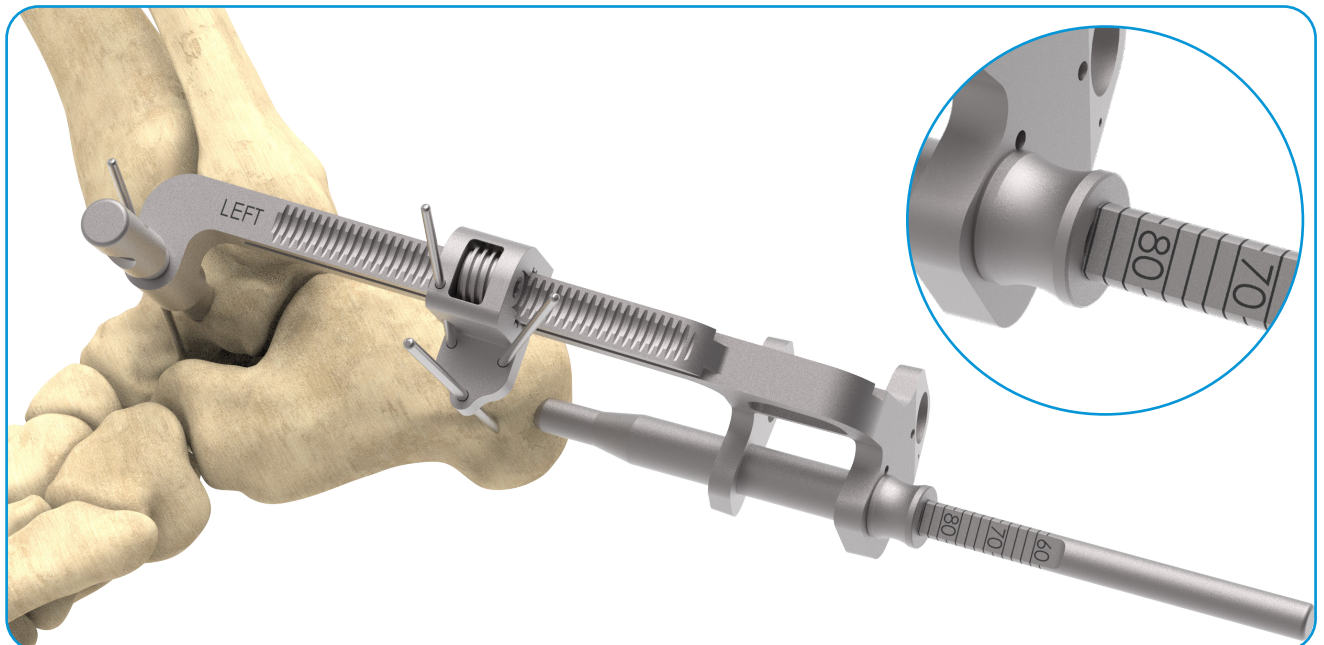

- 20.** Insert **5.5mm Screw** through pre-drilled tunnel until it reaches the **Post** and the rear screw head reaches the bone. Then rotationally advance until fully threaded into the **Post**. Do NOT attempt to drive **Screw** beyond hard stop. If **Screw** head is too prominent or buried too deep, remove **Screw** and select appropriate length.

NOTE: Care should be taken to ensure the 5.5mm Screw threads correctly into the Post without cross threading. Significant resistance prior to 5 full rotations is a sign of misalignment or cross threading.

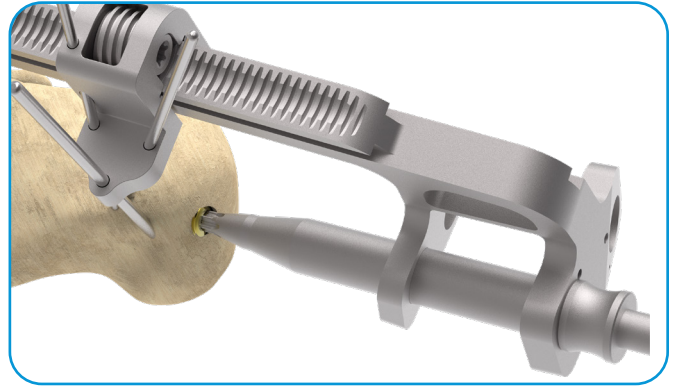
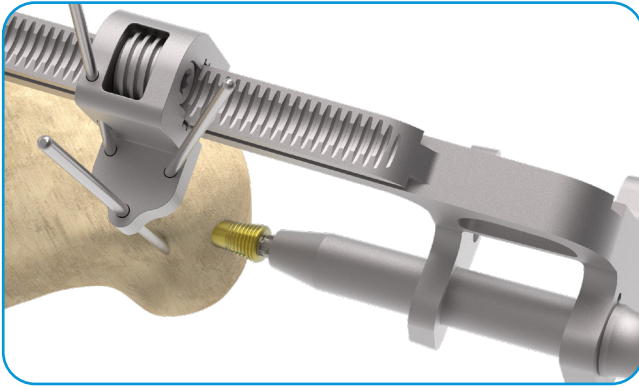

- 21.** Repeat the process of choosing the correct **Drill Bushing** and **Implant Bushing**, drilling, measuring for **5.5mm Screw** length, and screw placement for the dorsal **Screw**.

- 22.** To aid in removing **K-wires**, slightly reduce the compression by turning **Compression-Distraction Fixture Screw** counter-clockwise and remove all **K-wires**. Rotate **Post Fastener** counter-clockwise to release from **Post** and remove **Targeting Guide**.

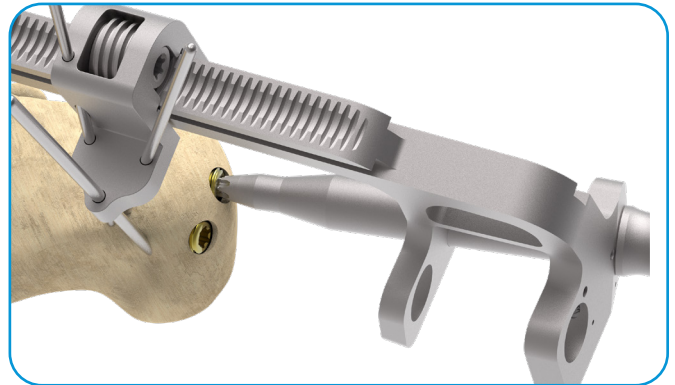

- 23.** Once both **5.5mm Screws** are fully threaded into the **Post**, thread the **Post Plug Screw** into the top of the **Post**.

- 24.** Close in the usual manner.

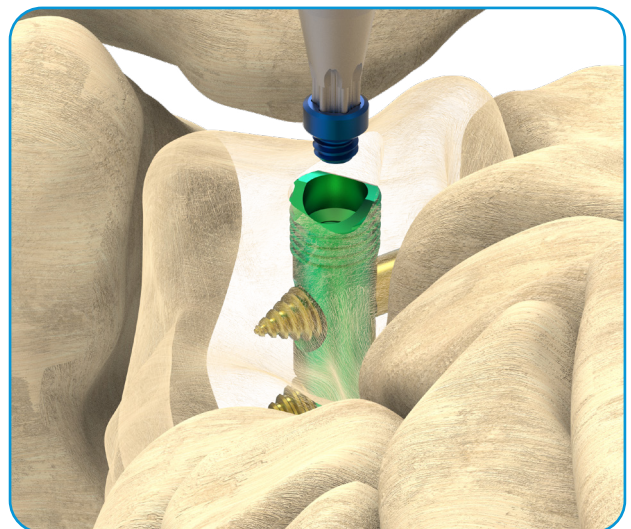

Revision Surgical Technique

1. Make a sinus tarsi incision laterally over the subtalar joint.
2. Locate the **Post** in the talus and clear bone to gain access.
3. Remove the **Post Plug Screw** using the **T25 InCore Driver**.
4. Make an incision in the heel. Locate the **5.5mm Screws** in the calcaneus and clear bone to gain access.
5. Remove both **5.5mm Screws** using the **T25 InCore Driver**.
6. Align the **Revision Guide** with the **Post**. Place the **Revision Post Fastener** through the **Revision Guide** and thread onto the **Post**. Hand tighten to stabilize the assembly.

NOTE: Reattaching Targeting Guide to Post can aid in locating 5.5mm screws in calcaneus.

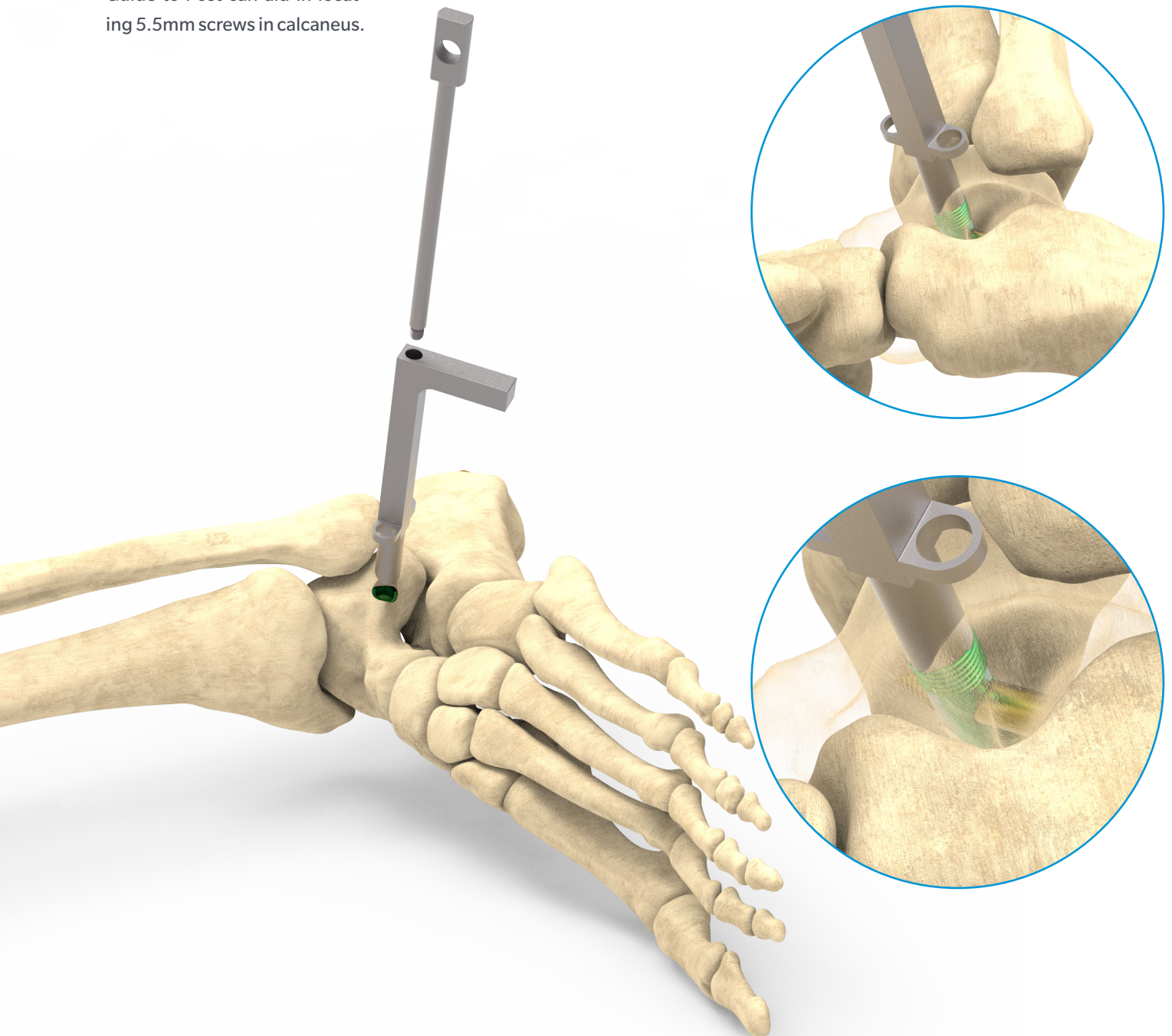

7. Review of removed screws and X-ray will indicate the presence of potential screw fragments. Long screw fragments should be removed using a standard screw removal system. If one or both screws have broken, leaving a small portion of the screw in the **Post**, run the **5.6mm Drill** through the guided hole on the side of the **Revision Guide** parallel to the **Post** until the screw fragment is reached.

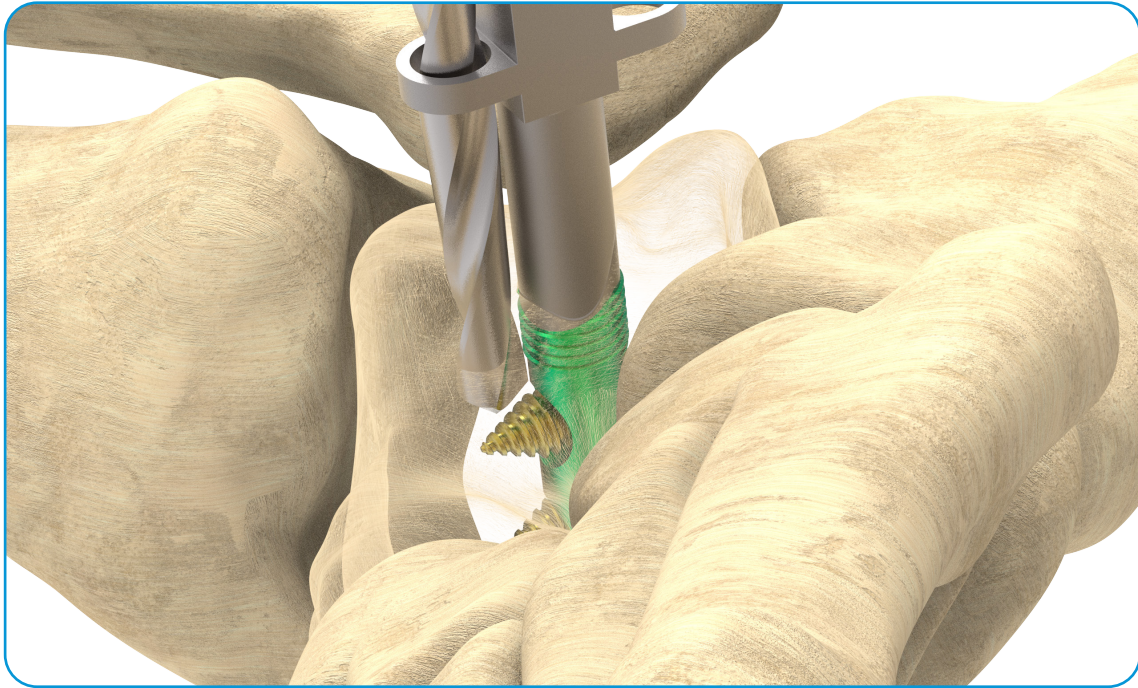

8. The **Revision Guide** can then be impacted laterally to remove the **Post**.
9. If additional inline force is required, the **Slap Hammer** can be attached by removing the **Revision Guide**, sliding the **Revision Post Fastener** through the **Slap Hammer** and reengaging with the **Post**.

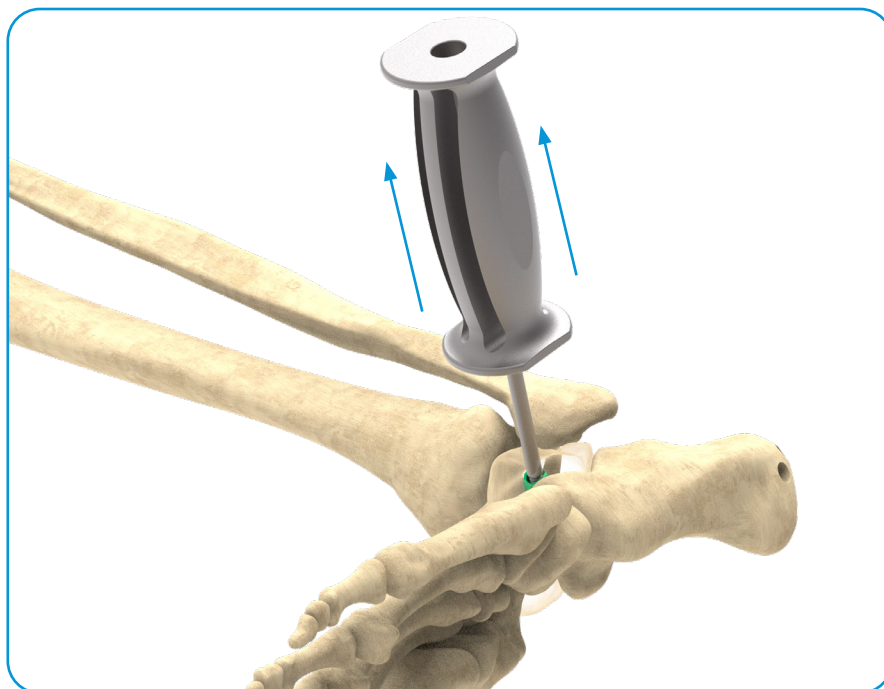

Ordering Information

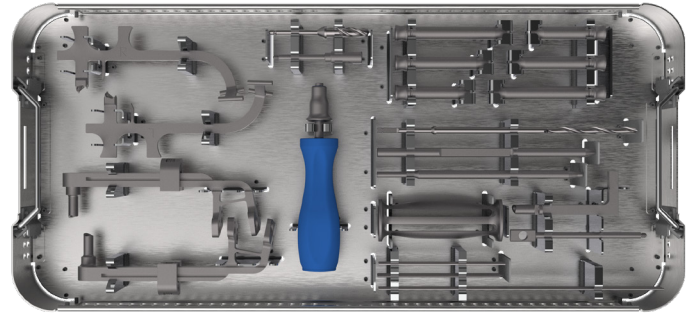

IMPLANTS

Part No.	Description
ICSUB80PR	InCore Subtalar 8.0mm x 28mm Right Titanium Post
ICSUB80PL	InCore Subtalar 8.0mm x 28mm Left Titanium Post
ICSUB55060	InCore Subtalar 5.5mm x 60mm Screw
ICSUB55062	InCore Subtalar 5.5mm x 62mm Screw
ICSUB55064	InCore Subtalar 5.5mm x 64mm Screw
ICSUB55066	InCore Subtalar 5.5mm x 66mm Screw
ICSUB55068	InCore Subtalar 5.5mm x 68mm Screw
ICSUB55070	InCore Subtalar 5.5mm x 70mm Screw
ICSUB55072	InCore Subtalar 5.5mm x 72mm Screw
ICSUB55074	InCore Subtalar 5.5mm x 74mm Screw
ICSUB55076	InCore Subtalar 5.5mm x 76mm Screw
ICSUB55078	InCore Subtalar 5.5mm x 78mm Screw
ICSUB55080	InCore Subtalar 5.5mm x 80mm Screw
ICSUB55082	InCore Subtalar 5.5mm x 82mm Screw
ICSUB55084	InCore Subtalar 5.5mm x 84mm Screw
ICSUB55086	InCore Subtalar 5.5mm x 86mm Screw
ICSUB55088	InCore Subtalar 5.5mm x 88mm Screw
ICSUB55090	InCore Subtalar 5.5mm x 90mm Screw
ICSUB55092	InCore Subtalar 5.5mm x 92mm Screw
ICSUB55094	InCore Subtalar 5.5mm x 94mm Screw
ICSUB55096	InCore Subtalar 5.5mm x 96mm Screw
ICSUB55098	InCore Subtalar 5.5mm x 98mm Screw
ICSUB55100	InCore Subtalar 5.5mm x 100mm Screw
ICSUB55102	InCore Subtalar 5.5mm x 102mm Screw
ICSUB55104	InCore Subtalar 5.5mm x 104mm Screw
ICSUB55106	InCore Subtalar 5.5mm x 106mm Screw
ICSUB55108	InCore Subtalar 5.5mm x 108mm Screw
ICSUB55110	InCore Subtalar 5.5mm x 110mm Screw
ICSUBPLUG	InCore Subtalar Post Plug Screw

INSTRUMENTS

Part No.	Description
ICSUBPGR	InCore Subtalar Post Guide Right
ICSUBPGL	InCore Subtalar Post Guide Left
ICSUBTGR	InCore Subtalar Targeting Guide Assembly Right
ICSUBTGL	InCore Subtalar Targeting Guide Assembly Left
ICSUBDBS	InCore Subtalar Drill Bushing, Small
ICSUBDBM	InCore Subtalar Drill Bushing, Medium
ICSUBDBL	InCore Subtalar Drill Bushing, Large
ICSUBIBS	InCore Subtalar Implant Bushing, Small
ICSUBIBM	InCore Subtalar Implant Bushing, Medium
ICSUBIBL	InCore Subtalar Implant Bushing, Large
ICSUBPF	InCore Subtalar Post Fastener
ICSUB80PD	InCore Subtalar 8.0mm Post Drill
ICSUBT25	InCore Subtalar T25 Driver
ICSUB56DB	InCore Subtalar 5.6mm Drill Bit
ICSUBRDG	InCore Subtalar Removal Drill Guide
ICSUBRSH	InCore Subtalar Removal Slap Hammer
ICSUBRF	InCore Subtalar Removal Fastener
ICSUBDP	InCore Subtalar Depth Probe
ICSUBTLH	InCore Subtalar Torque Limiting Handle
ICSUBCASE	InCore Subtalar Instrument Case
ICSUBLID	InCore Subtalar Instrument Case Lid
ICSUB80PDD	InCore Subtalar 8.0mm Post Drill Disposable
ICSUBT25D	InCore Subtalar T25 Driver Disposable
ICSUB56DBD	InCore Subtalar 5.6mm Drill Bit Disposable
ICSUBKWST	InCore Subtalar K-wires, Sterile: 4 – 2.0mm x 4" K-wires 3 – 2.0mm x 9" K-wires 2 – 2.4mm x 4" K-wires
ICSUBCFR	InCore Subtalar Replacement Compression Frame Right
ICSUBCFL	InCore Subtalar Replacement Compression Frame Left
ICSUBCS	InCore Subtalar Replacement Compression Screw

For complete product information including indications, contraindications, warnings, precautions, potential adverse effects and patient counselling information, see the package insert or contact your local representative; visit www.zimmerbiomet.com for additional product information.

Zimmer Biomet does not practice medicine. This technique was developed in conjunction with health care professional. A written copy of the surgical technique is available at www.zimmerbiomet.com. Each surgeon should exercise his or her own independent judgment in the diagnosis and treatment of an individual patient, and this information does not purport to replace the comprehensive training surgeons have received. As with all surgical procedures, the technique used in each case will depend on the surgeon's medical judgment as the best treatment for each patient. Results will vary based on health, weight, activity and other variables. Not all patients are candidates for this product and/or procedure. Caution: Federal (USA) law restricts this device to sale by or on the order of a surgeon. Rx only.

All content herein is protected by copyright, trademarks and other intellectual property rights, as applicable, owned by or licensed to Zimmer Biomet or its affiliates unless otherwise indicated, and must not be redistributed, duplicated or disclosed, in whole or in part, without the express written consent of Zimmer Biomet.

The InCore Subtalar System is manufactured using Ti 6-4 ELI.



Distributed by:

Zimmer, Inc.
1800 West Center St.
Warsaw, IN 46580 U.S.A.
(800) 613-6131
contactus@zimmerbiomet.com



Legal Manufacturer:

Medartis Inc.
1195 Polk Drive
Warsaw, IN 46580 U.S.A.
(732) 383-7901
medartisa.com